

USER'S MANUAL

MANO566 - DDR5(V.B)

**Intel® Socket 1700 Core™ i9/ i7/ i5/ i3
Series Processors Mini ITX
Motherboard**

User's Manual



www.axiomtek.com

Disclaimers

This manual has been carefully checked and believed to contain accurate information. Axiomtek Co., Ltd. assumes no responsibility for any infringements of patents or any third party's rights, and any liability arising from such use.

Axiomtek does not warrant or assume any legal liability or responsibility for the accuracy, completeness or usefulness of any information in this document. Axiomtek does not make any commitment to update the information in this manual.

Axiomtek reserves the right to change or revise this document and/or product at any time without notice.

No part of this document may be reproduced, stored in a retrieval system, or transmitted, in any form or by any means, electronic, mechanical, photocopying, recording, or otherwise, without the prior written permission of Axiomtek Co., Ltd.

CAUTION

If you replace wrong batteries, it causes the danger of explosion. It is recommended by the manufacturer that you follow the manufacturer's instructions to only replace the same or equivalent type of battery, and dispose of used ones.

©Copyright 2025 Axiomtek Co., Ltd.

All Rights Reserved

August 2025, Version A1

Printed in Taiwan

ESD Precautions

Computer boards have integrated circuits sensitive to static electricity. To prevent chipsets from electrostatic discharge damage, please take care of the following jobs with precautions:

- Do not remove boards or integrated circuits from their anti-static packaging until you are ready to install them.
- Before holding the board or integrated circuit, touch an unpainted portion of the system unit chassis for a few seconds. It discharges static electricity from your body.
- Wear a wrist-grounding strap, available from most electronic component stores, when handling boards and components.

Trademarks Acknowledgments

Axiomtek is a trademark of Axiomtek Co., Ltd.

Intel® and Celeron® are trademarks of Intel Corporation.

Windows® is a trademark of Microsoft Corporation.

AMI is a trademark of American Megatrend Inc.

IBM, PC/AT, PS/2, VGA are trademarks of International Business Machines Corporation.

Other brand names and trademarks are the properties and registered brands of their respective owners.

Table of Contents

Disclaimers	ii
ESD Precautions.....	iii
Section 1 Introduction.....	1
1.1 Features	1
1.2 Specifications	2
1.3 Utilities Supported	3
1.4 Block Diagram.....	4
Section 2 Board and Pin Assignments.....	5
2.1 Board Layout.....	5
2.3 Jumper and Switch Settings.....	6
2.3.1 Auto Power On (JP1)	7
2.3.2 EDP VDD Select (JP4).....	7
2.3.3 Clear CMOS (SW1).....	7
2.4 Connectors.....	8
2.4.1 Fan Connectors (CN1 CPU Fan and CN2 SYS Fan)	9
2.4.2 ATX Power Input Connectors (CN3 and CN4).....	9
2.4.3 USB 2.0 Wafer Connector (CN5 and CN26).....	10
2.4.4 M.2 Key M Connector (CN7).....	11
2.4.5 M.2 Key E Connector (CN8)	12
2.4.6 Front Panel Connector (CN9)	13
2.4.7 Nano SIM Socket (CN10) (Optional).....	14
2.4.8 SATA Connectors (CN11 and CN12).....	14
2.4.9 M.2 Key B Connector (CN13) (Optional)	15
2.4.10 COM Wafer Connectors (CN14 and CN16)	16
2.4.11 Digital I/O Wafer Connector (CN15).....	16
2.4.12 LAN and USB 3.2 Ports (CN17 and CN18)	17
2.4.13 DisplayPort++ and HDMI Connector (CN19) (Optional)	18
2.4.14 Audio Jack (CN20)	18
2.4.15 COM Double-deck D-Sub Connector (CN21)	19
2.4.16 HDMI Type-A Connector (CN22).....	19
2.4.17 PCI-Express x16 Slots (CN24).....	22
2.4.18 eDP Connector (SCN2).....	22
Section 3 Hardware Description	23
3.1 Microprocessors.....	23
3.2 BIOS.....	23
3.3 System Memory	23

3.4	I/O Port Address Map	24
3.5	Interrupt Controller (IRQ) Map.....	25
3.6	Memory Map	30
Section 4 AMI BIOS Setup Utility		31
4.1	Starting.....	31
4.2	Navigation Keys	31
4.3	Main Menu	33
4.4	Advanced Menu	34
4.5	Chipset Menu	43
4.6	Security Menu	47
4.7	Boot Menu.....	48
4.8	Save & Exit Menu.....	51
Appendix A Watchdog Timer		53
A.1	About Watchdog Timer	53
A.2	Sample Program	53
Appendix B Digital I/O.....		55
B.1	Digital I/O Programming	55
B.2	Sample Code	56
Appendix C iAMT Settings.....		60
D.1	Entering MEBx	60
D.2	Set and Change Password.....	61
D.3	iAMT Settings.....	61
D.4	iAMT Web Console	62
Appendix D TPM Settings		65
Appendix E VMD(RAID) Configuration		75

This page is intentionally left blank.

Section 1

Introduction

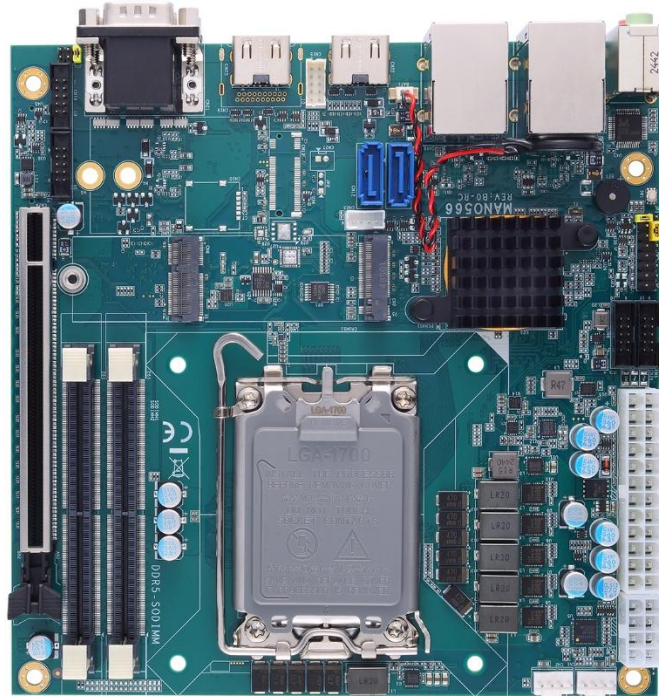

The MANO566 Mini-ITX motherboard supports the new Intel 7 14th/ 13th/ 12th Generation Intel® Core™ i9/ i7/ i5/ i3 (65W CPU) and Pentium® processors in LGA1700 package. Featuring the new Intel® H610, Q670E, R680E Express chipset with two DDR5 5600MHz memory support, this motherboard is built to perform best stability and reliability for industrial applications.

It comes with two SATA 3.0, four USB 3.2, four USB 2.0 and four serial ports providing robust storage and I/O options. Users also can increase board functionality with PCI-Express x16 and M.2 slot. The high quality MANO566 allows max. four display interfaces via eDP, DisplayPort++ and two HDMI(DP is optional), making it an ideal solution for gaming, workstation, digital signage, medical and other IoT&M2M applications.

1.1 Features

- LGA1700 Socket for 14th/ 13th/ 12th Generation Intel® Core™ i9/ i7/ i5/ i3 processors and Pentium® processor (up to 65W) (Alder Lake-S)
- 2 DDR5-5600MHz memory with maximum capacity up to 96 GB
- 1 PCI-Express x16(Gen4)
- 1 M.2 Key E 2230 for WiFi (support PCIE(Gen3) x1, USB 2.0 signal)
- 1 M.2 Key M 2280 for NVMe storage (support PCIE(Gen3) x4 signal)
- 2 SATA-600 support RAID 0/1.
- 4 USB 3.2 and 4 USB 2.0
- TPM 2.0 (optional).

1.2 Specifications

- **CPU**
 - LGA1700Socket for 14th/ 13th/ 12th Generation Intel® Core™ i9/ i7/ i5/ i3 processors and Pentium® processor (up to 65W CPU).
- **Chipset**
 - Intel® H610
 - Intel® Q670E
 - Intel® R680E
- **BIOS**
 - AMI BIOS via SPI interface.
- **System Memory**
 - Two 262-pin SO-DIMM sockets.
 - Supports up to 48GB per DIMM, with a maximum total memory capacity of 96GB using two DIMMs.
 - Support 4800/5200/5600 MHz.
- **Onboard Multi I/O**
 - Controller: F81966
 - Four serial ports:
 - COM1~2 with RS-232/422/485 by BIOS selectable (Rear I/O)
 - COM3~4 with RS-232 (2x5P 2.0mm box header)
- **USB Interface**
 - Four USB 3.2 Ports (on the rear I/O).
 - R680E / Q670E: 4 ports USB3.2 Gen2x1
 - H610 : 2 ports USB3.2 Gen2x1(CN17) + 2 ports USB3.2 Gen1x1(CN18)
 - Four USB 2.0 Ports via 2x5 pin 2.0mm wafer (internal).
- **Ethernet**

Two 2500/1000/100/10Mbps Gigabit/Fast Ethernet support Wake-on-LAN, PXE via Intel® I226-V (H610 & Q670E SKU) and Intel® I226-LM. (R680E SKU)
- **Serial ATA**
 - Two SATA 3.0 ports (6Gb/s).
- **Audio**
 - Realtek ALC888 HDA codec.
 - Support MIC-in/line-out (on the rear I/O).
 - Support MIC-in/line-out/line-in in box header (internal).
- **Display**
 - Two HDMI 1.4b connector in wafer connector. Resolution max. up to 4096x2160@30Hz.
 - One DisplayPort++ with resolution max. up to 4096x2160 @60Hz. (Optional)
 - One Embedded DisplayPort (eDP) with resolution max. up to 4096x2160@60Hz.
- **Expansion Interface**
 - One PCI-Express(Gen4) x16 slot.
 - One M.2 key M slot (support PCIE x4 signal).
 - One M.2 Key E slot (support PCIE x1, USB 2.0 signal).
 - One M.2 Key B slot (support PCIE x1, USB 3.2 signal) (Optional)
- **Power Input**

- One ATX power input connector.
- One 12V ATX power input connector for CPU power.

- **Operating Temperature**
 - 0°C ~ 60°C.

- **Storage Temperature**
 - -20°C ~ 65°C.

- **Form Factor**
 - Mini ITX (6.7" x 6.7", 17.0cm x 17.0cm).



All specifications and images are subject to change without notice.

Note

1.3 Utilities Supported

- Chipset driver
- Graphics driver
- Intel ME driver
- Ethernet driver
- Serial IO driver
- Intel RST driver
- Intel DTT driver
- Intel GNA driver (13th/14th support only)

Section 2

Board and Pin Assignments

2.1 Board Layout

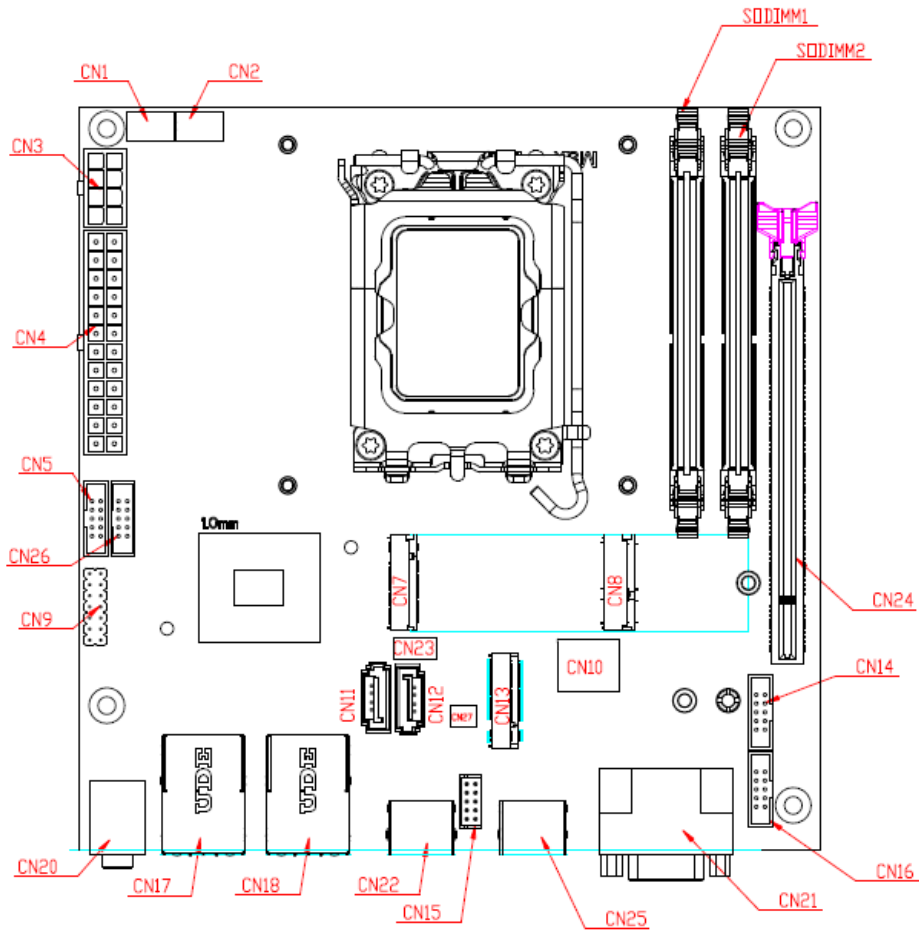

Top View

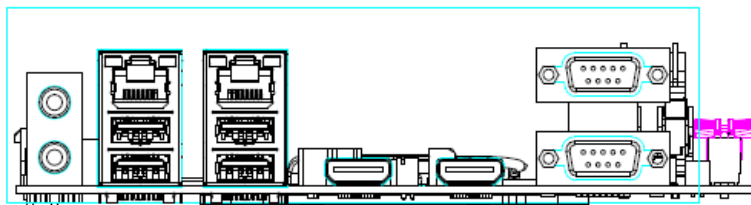

Rear I/O



Note

To identify the first pin of a header or jumper, please refer to the following information:

- Usually, there is a thick line or a triangle near the header or jumper pin 1.

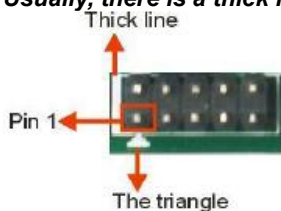

2.3 Jumper and Switch Settings

Jumper is a small component consisting of jumper clip and jumper pins. Install jumper clip on 2 jumper pins to close. And remove jumper clip from 2 jumper pins to open. The following illustration shows how to set up jumper.

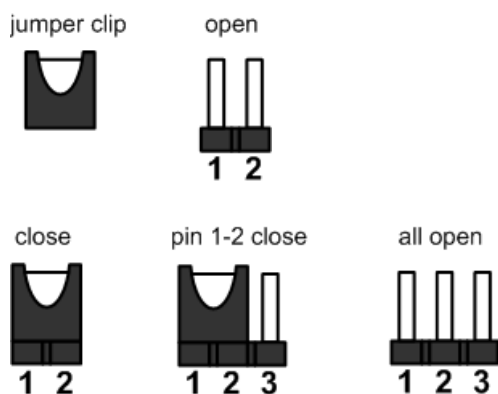

Before applying power to MANO566 Series, please make sure all of the jumper and switch are in factory default position. Below you can find a summary table of jumper, switch and onboard default settings.



Note

Once the default jumper and switch settings need to be changed, please do it under power-off condition.

Jumper	Description	Setting
JP1	Auto Power On Default: Disable	2-3 Close
JP4	EDP VDD Select Default: +3.3V	1-2 Close
SW1	Clear CMOS Default: Normal Operation	Release

2.3.1 Auto Power On (JP1)

If JP1 is enabled for power input, the system will be automatically power on without pressing soft power button. If JP1 is disabled for power input, it is necessary to manually press soft power button to power on the system.

Function	Setting
Enable auto power on	1-2 close
Disable auto power on (Default)	2-3 close



2.3.2 EDP VDD Select (JP4)

The motherboard supports voltage selection for embedded DisplayPort (eDP). Use this jumper to set up VDD power of the eDP connector. To prevent hardware damage, before connecting please make sure that the input voltage of display panel is correct.

Function	Setting
+3.3V (Default)	1-2 close
+5V	2-4 or 4-6 close
+12V	5-6 close

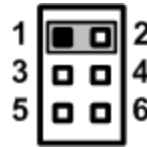

2.3.3 Clear CMOS (SW1)

This switch allows you to clear the Real Time Clock (RTC) RAM in CMOS. You can clear the CMOS memory of date, time, and system setup parameters by erasing the CMOS RTC RAM data. The onboard button cell battery powers the RAM data in CMOS, which includes system setup information such as system passwords.

To erase the RTC RAM:

1. Turn OFF the computer and unplug the power cord.
2. Remove the onboard battery.
3. Press the tact switch for at least 1 second.
4. Re-install the battery.
5. Plug the power cord and turn ON the computer.
6. Hold down the key during the boot process and enter BIOS setup to re-enter data.

Function	Setting
Normal (Default)	Release
Restore BIOS optimal defaults	Press

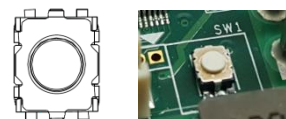

2.4 Connectors

Signals go to other parts of the system through connectors. Loose or improper connection might cause problems, please make sure all connectors are properly and firmly connected. Here is a summary table showing connectors on the hardware.

Connector	Description
CN1, CN2	Fan Wafer Connectors
CN3, CN4	ATX Power Input Connectors
CN5, CN26	USB 2.0 Wafer Connectors
CN7	M.2 Key M Connector
CN8	M.2 Key E Connector
CN9	Front Panel Connector
CN10	Nano SIM Socket
CN11, CN12	SATA 3.0 Connectors
CN13	M.2 Key B Connector
CN14, CN16	COM3 and COM4 Wafer Connectors
CN15	Digital I/O Wafer Connector
CN17, CN18	LAN and USB 3.2 Ports
CN19	DisplayPort++ and HDMI Connector
CN20	Audio Jack
CN21	COM Double-deck D-Sub Connector
CN22	HDMI Type-A Connector
CN24	PCIe x16 Slot (Gen4)
DIMM1, DIMM2	DDR5 SO-DIMM CHA~CHB Connectors
SCN2	eDP Connector

2.4.1 Fan Connectors (CN1 CPU Fan and CN2 SYS Fan)

The motherboard has two 4-pin (pitch=2.54mm) fan connectors. You can find fan speed option within BIOS Setup Utility if fan is installed. For further information, see BIOS Setup Utility: Advanced\Hardware Monitor\PC Health Status in section 4.4.

Pin	Signal
1	GND
2	+12V
3	FAN Speed Detection
4	FAN Speed Control

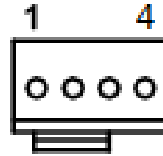

2.4.2 ATX Power Input Connectors (CN3 and CN4)

Steady and sufficient power can be supplied to all components on the board by connecting power connector. Please make sure all components and devices are properly installed before connecting the power connector.

External power supply plug fits into the connector in only one orientation. Properly press down power supply plug until it completely and firmly fits into this connector. Loose connection may cause system instability.

CN3: 8-pin connector for +12V DC power input.

Pin	Signal	Pin	Signal
1	GND	5	+12V
2	GND	6	+12V
3	GND	7	+12V
4	GND	8	+12V

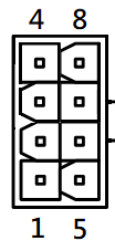

CN4: 24-pin connector for DC power input.

Pin	Signal	Pin	Signal
1	3.3V	13	3.3V
2	3.3V	14	-12V
3	GND	15	GND
4	+5V	16	PS_ON
5	GND	17	GND
6	+5V	18	GND
7	GND	19	GND
8	PWR OK	20	-5V
9	5VSB	21	+5V
10	+12V	22	+5V
11	+12V	23	+5V
12	3.3V	24	GND

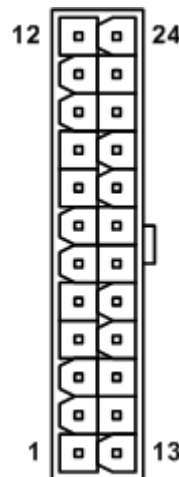

2.4.3 USB 2.0 Wafer Connector (CN5 and CN26)

These are 2x5-pin (Pitch=2.00mm/Model: 520-90-10GB00) connectors for USB 2.0 interfaces.

CN5/CN26:

Pin	Signal	Pin	Signal
1	USB VCC (+5V_SBY)	2	USB VCC (+5V_SBY)
3	USB_D5_N	4	USB_D6_N
5	USB_D5_P	6	USB_D6_P
7	GND	8	GND
9	GND	10	GND

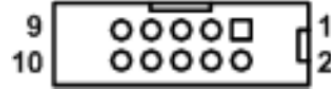

2.4.4 M.2 Key M Connector (CN7)

The motherboard comes with one M.2 Key M connector suitable for mounting SATA/PCIE storage card.

Pin	Signal	Pin	Signal
1	GND	2	+3.3V
3	GND	4	+3.3V
5	PCIE_RX3_N	6	NC
7	PCIE_RX3_P	8	NC
9	GND	10	NC
11	PCIE_TX3_N	12	+3.3V
13	PCIE_TX3_P	14	+3.3V
15	GND	16	+3.3V
17	PCIE_RX2_N	18	+3.3V
19	PCIE_RX2_P	20	NC
21	GND	22	NC
23	PCIE_TX2_N	24	NC
25	PCIE_TX2_P	26	NC
27	GND	28	NC
29	PCIE_RX1_N	30	NC
31	PCIE_RX1_P	32	NC
33	GND	34	NC
35	PCIE_TX1_N	36	NC
37	PCIE_TX1_P	38	DEVSLP
39	GND	40	NC
41	PCIE_RX0_N	42	NC
43	PCIE_RX0_P	44	NC
45	GND	46	NC
47	PCIE_TX0_N	48	NC
49	PCIE_TX0_P	50	PERST#
51	GND	52	CLKREQ#
53	REF_CLK_N	54	PEWAKE#
55	REF_CLK_P	56	NC
57	GND	58	NC
59	Key M	60	Key M
61			
63			
65			
67	NC	68	SUSCLK
69	NC	70	+3.3V
71	GND	72	+3.3V
73	GND	74	+3.3V
75	GND		

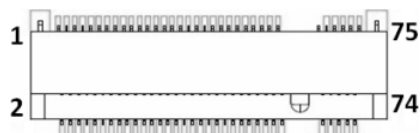

2.4.5 M.2 Key E Connector (CN8)

The motherboard comes with one M.2 Key E connector.

Pin	Signal	Pin	Signal
1	GND	2	+3.3V
3	USB_D+	4	+3.3V
5	USB_D-	6	NC
7	GND	8	NC
9	NC	10	NC
11	NC	12	NC
13	NC	14	NC
15	NC	16	NC
17	NC	18	GND
19	NC	20	NC
21	NC	22	NC
23	NC	24	KEY E
25	KEY E	26	
27		28	
29		30	
31		32	NC
33	GND	34	NC
35	PCIE_TX_P	36	NC
37	PCIE_TX_N	38	NC
39	GND	40	NC
41	PCIE_RX_P	42	NC
43	PCIE_RX_N	44	NC
45	GND	46	NC
47	REF_CLK_P	48	NC
49	REF_CLK_N	50	SUSCLK
51	GND	52	PERST#
53	CLKREQ#	54	W_DISABLE2#
55	PEWAKE#	56	W_DISABLE1#
57	GND	58	I2C_DAT
59	NC	60	I2C_CLK
61	NC	62	ALERT#
63	GND	64	NC
65	NC	66	NC
67	NC	68	NC
69	GND	70	NC
71	NC	72	+3.3V
73	NC	74	+3.3V
75	GND		

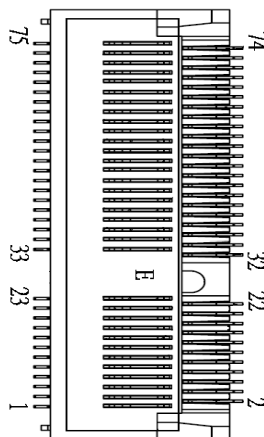

2.4.6 Front Panel Connector (CN9)

The CN9 is a 2x7-pin (pitch=2.54mm) header for front panel interface.

Pin	Signal
1	Power LED+
2	SPK-
3	GND
4	BUZZER-
5	Power LED-
6	NC
7	NC
8	SPK+
9	PWRSW-
10	PWRSW+
11	HWRST-
12	HWRST+
13	HDDLED-
14	HDDLED+

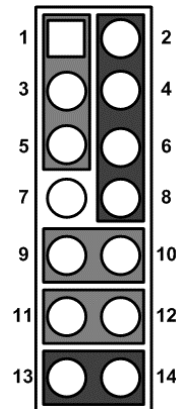

Power LED

Pin 1 connects LED+ and pin 5 connects LED-. The power LED lights up when the system is powered on.

External Speaker and Internal Buzzer

Pin 2, 4, 6 and 8 connect the case-mounted speaker unit or internal buzzer. While connecting the board to an internal buzzer, please set pin 2 and 4 closed; while connecting to an external speaker, you need to set pins 2 and 4 opened and connect the speaker cable to pin 8(+) and pin 2(-).

Power On/Off Button

Pin 9 and 10 connect the power button on front panel to the board, which allows users to turn on or off power supply.

System Reset Switch

Pin 11 and 12 connect the case-mounted reset switch that reboots your computer without turning off the power switch. It is a better way to reboot your system for a longer life of system power supply.

HDD Activity LED

This connection is linked to hard drive activity LED on the control panel. LED flashes when HDD is being accessed. Pin 13 and 14 connect the hard disk drive to the front panel HDD LED, pin 13 is assigned as cathode(-) and pin 14 is assigned as anode(+).

2.4.7 Nano SIM Socket (CN10) (Optional)

The motherboard is equipped with CN10 socket for inserting SIM Card. This function is not available in the standard model(H610 SKU/Q670E SKU), but it is offered as an optional feature. Please contact your sales representative for more information.

Pin	Signal
C1	SIM VCC
C2	SIM Reset
C3	SIM CLK
C5	GND
C6	SIM VPP
C7	SIM Data

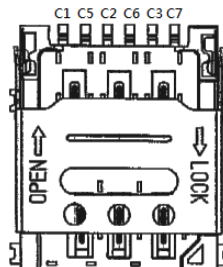

2.4.8 SATA Connectors (CN11 and CN12)

This Serial Advanced Technology Attachment (Serial ATA or SATA) connector is for SATA 3.0 interface allowing up to 6.0Gb/s data transfer rate. It is a computer bus interface for connecting to device such as hard disk drive.

CN11/CN12:

Pin	Signal
1	GND
2	SATA_4_TX_P
3	SATA_4_TX_N
4	GND
5	SATA_4_RX_N
6	SATA_4_RX_P
7	GND



2.4.9 M.2 Key B Connector (CN13) (Optional)

The motherboard comes with one M.2 Key B connector suitable for mounting SATA/PCIE storage card, or USB 3.2 and USB 2.0 application card. This function is not available in the standard model(H610 SKU/Q670E SKU), but it is offered as an optional feature. Please contact your sales representative for more information.

Pin	Signal	Pin	Signal
1	CONFIG_3	2	+3.3V_SBY
3	GND	4	+3.3V_SBY
5	GND	6	Full Card PWR OFF_SBY (+1.8V)
7	USB_DP	8	W_DISABLE1#_SBY (+3.3V)
9	USB_DN	10	NC
11	GND	12	Key B
13	Key B	14	
15		16	
17		18	
19		20	NC
21	CONFIG_0	22	NC
23	GPIO_11_SBY (+1.8V)	24	NC
25	NC	26	NC
27	GND	28	NC
29	USB3_RX_N	30	SIM_RESET
31	USB3_RX_P	32	SIM_CLK
33	GND	34	SIM_DATA
35	USB3_TX_N	36	SIM_PWR
37	USB3_TX_P	38	NC
39	GND	40	SMB_CLK_SBY (+1.8V)
41	PCIE_RX_N	42	SMB_DATA_SBY (+1.8V)
43	PCIE_RX_P	44	NC
45	GND	46	NC
47	PCIE_TX_N	48	NC
49	PCIE_TX_P	50	PERST#
51	GND	52	CLKREQ#
53	REF_CLK_N	54	PEWAKE#
55	REF_CLK_P	56	NC
57	GND	58	NC
59	NC	60	NC
61	NC	62	NC
63	NC	64	NC
65	NC	66	NC
67	RESET#_SBY (+1.8V)	68	SUSCLK
69	CONFIG_1	70	+3.3V_SBY
71	GND	72	+3.3V_SBY
73	GND	74	+3.3V_SBY
75	CONFIG_2		

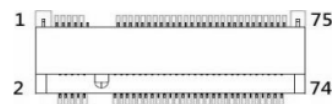

2.4.10 COM Wafer Connectors (CN14 and CN16)

The motherboard comes with two 2x5-pin (Pitch=2.00mm/Model: 520-90-10GB00) wafer connectors for COM3 and COM4 serial port interfaces. Both COM3 and COM4 are selectable for RS-232. The pin assignments of RS-232 are listed in table below. (Maximum baud rate 115200bit/s)

Pin	RS-232
1	DCD#
2	RXD
3	TXD
4	DTR#
5	GND
6	DSR#
7	RTS#
8	CTS#
9	RI#

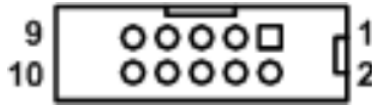

2.4.11 Digital I/O Wafer Connector (CN15)

The motherboard comes with a 2x5-pin (Pitch=2.00mm / Model:2417SJ-10-PHD) header for 8-bit digital I/O interface.

Pin	Signal	Pin	Signal
1	DIO1	2	DIO8
3	DIO2	4	DIO7
5	DIO3	6	DIO6
7	DIO4	8	DIO5
9	+5V	10	GND

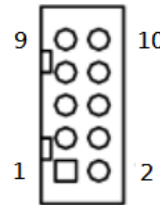

2.4.12 LAN and USB 3.2 Ports (CN17 and CN18)

The motherboard comes with two high performance plug and play Ethernet interfaces (RJ-45) which are fully compliant with the IEEE 802.3 standard. Connection can be established by plugging one end of the Ethernet cable into this RJ-45 connector and the other end to a 2500/1000/100/10 Base-T hub.

* Only CN17 with R680E SKU supported Intel AMT(Active Management Technology)

The Universal Serial Bus (compliant with USB 3.2) connectors on the rear I/O are for installing USB peripherals such as keyboard, mouse, scanner, etc.

* **R680E / Q670E**: 4 × USB 3.2 Gen2x1 ports

* **H610E**: 2 × USB 3.2 Gen2x1 ports (CN17) + 2 × USB 3.2 Gen1x1 ports (CN18)

Pin	LAN Signal	Pin	LAN Signal
L1	LAN1_MDI0_P	L2	LAN1_MDI0_N
L3	LAN1_MDI1_P	L4	LAN1_MDI1_N
L5	LAN1_MDI2_P	L6	LAN1_MDI2_N
L7	LAN1_MDI3_P	L8	LAN1_MDI3_N
A	10/100M LED (Non) 1000M LED(Orange) 2500M LED(Green)		
B	Active LED(Yellow)		
Pin	USB Signal	Pin	USB Signal
1	+5V	10	+5V
2	USB#1_D-	11	USB#2_D-
3	USB#1_D+	12	USB#2_D+
4	GND	13	GND
5	USB#1_SSRX-	14	USB#2_SSRX-
6	USB#1_SSRX+	15	USB#2_SSRX+
7	GND	16	GND
8	USB#1_SSTX	17	USB#2_SSTX
9	USB#1_SSTX+	18	USB#2_SSTX+

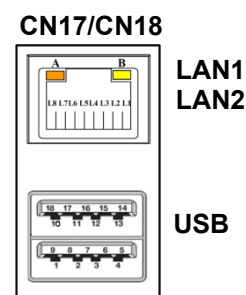

2.4.13 DisplayPort++ and HDMI Connector (CN19) (Optional)

The motherboard comes with DisplayPort++ and HDMI interface on the rear I/O. The DP port is not included in the standard models (H610 SKU / Q670E SKU), but is available as an optional feature. For more information, please contact your sales representative.

Pin	Signal	Pin	Signal
1	LANE 0	21	DATA2
2	GND	22	GND
3	LANE 0#	23	DATA2#
4	LANE 1	24	DATA1
5	GND	25	GND
6	LANE 1#	26	DATA1#
7	LANE 2	27	DATA0
8	GND	28	GND
9	LANE 2#	29	DATA0#
10	LANE 3	30	Clock
11	GND	31	GND
12	LANE 3#	32	Clock#
13	Detect Pin	33	NC
14	GND	34	NC
15	AUX CH	35	SCL
16	GND	36	SDA
17	AUX CH#	37	GND
18	Hot Plug Detect	38	+5V POWER
19	GND	39	Hot Plug Detect
20	DP_PWR(3.3V)		

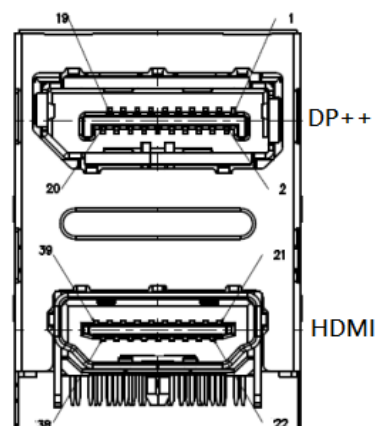

2.4.14 Audio Jack (CN20)

The motherboard provides HD audio jack on the rear I/O. Install audio driver, and then attach audio devices to CN20.

Pin Color	Signal
Green	Line-out
Pink	MIC-in



2.4.15 COM Double-deck D-Sub Connector (CN21)

The CN21 is a double-deck D-Sub connector for COM1 and COM2 serial port interfaces. Both COM1 and COM2 are selectable for RS-232/422/485 mode by BIOS setting (see section 4.4). The pin assignments of RS-232/422/485 are listed in table below. (Maximum baud rate 115200bit/s)

COM1 and COM2:

Pin	RS-232	RS-422	RS-485
1	DCD#	TX-	485-
2	RXD	TX+	485+
3	TXD	RX+	N/C
4	DTR#	RX-	N/C
5	GND	GND	GND
6	DSR#	N/C	N/C
7	RTS#	N/C	N/C
8	CTS#	N/C	N/C
9	RI#	N/C	N/C

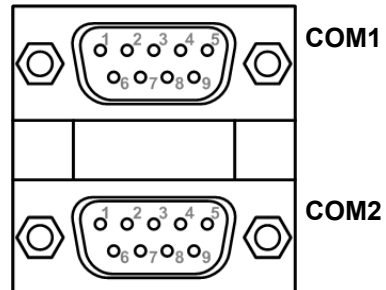

2.4.16 HDMI Type-A Connector (CN22)

The HDMI (High-Definition Multimedia Interface) is a compact digital interface which is capable of transmitting high-definition video and high-resolution audio over a single cable.

Pin	Signal
1	DATA2
2	GND
3	DATA2#
4	DATA1
5	GND
6	DATA1#
7	DATA0
8	GND
9	DATA0#
10	Clock
11	GND
12	Clock#
13	NC
14	NC
15	SCL
16	SDA
17	GND
18	+5V POWER
19	Hot Plug Detect

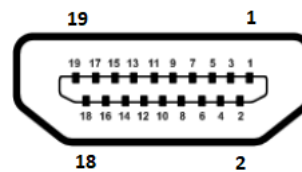

2.4.17 PCI-Express x16 Slots (CN24)

The motherboard supports one PCI-Express x16 slots (Gen4).

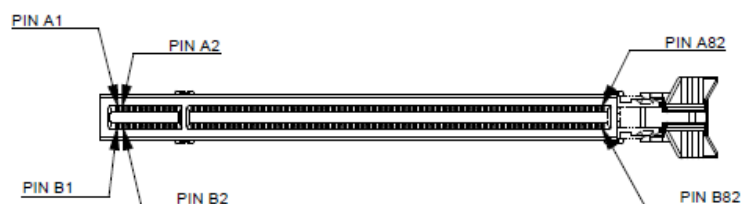

Pin	Signal	Pin	Signal
B1	+12V_PS	A1	GND
B2	+12V_PS	A2	+12V_PS
B3	+12V_PS	A3	+12V_PS
B4	GND	A4	GND
B5	SMB_CLK_RESUME	A5	N/C
B6	SMB_DATA_RESUME	A6	N/C
B7	GND	A7	N/C
B8	+3.3V_PS	A8	N/C
B9	N/C	A9	+3.3V_PS
B10	+3.3V_SB	A10	+3.3V_PS
B11	PCH_WAKE_N	A11	PWRGD
B12	N/C	A12	GND
B13	GND	A13	CLKOUT_PCIE_P5
B14	PCIE1_SLOT1_TX_DP_C	A14	CLKOUT_PCIE_N5
B15	PCIE1_SLOT1_TX_DN_C	A15	GND
B16	GND	A16	PCIE1_SLOT1_RX_DP_C
B17	PCIE4_SLOT1_PRSENT2_N	A17	PCIE1_SLOT1_RX_DN_C
B18	GND	A18	GND
B19	PCIE2_TX_DP	A19	N/C
B20	PCIE2_TX_DN	A20	GND
B21	GND	A21	PCIE2_RX_DP
B22	GND	A22	PCIE2_RX_DN
B23	PCIE3_TX_DP	A23	GND
B24	PCIE3_TX_DN	A24	GND
B25	GND	A25	PCIE3_RX_DP
B26	GND	A26	PCIE3_RX_DN
B27	PCIE4_TX_DP	A27	GND
B28	PCIE4_TX_DN	A28	GND
B29	GND	A29	PCIE4_RX_DP
B30	N/C	A30	PCIE4_RX_DN
B31	N/C	A31	GND
B32	GND	A32	N/C
B33	PCIE5_TX_DP	A33	N/C
B34	PCIE5_TX_DN	A34	GND
B35	GND	A35	PCIE5_RX_DP
B36	GND	A36	PCIE5_RX_DN
B37	PCIE6_TX_DP	A37	GND
B38	PCIE6_TX_DN	A38	GND
B39	GND	A39	PCIE6_RX_DP

B40	GND	A40	PCIE6_RX_DN
B41	PCIE7_TX_DP	A41	GND
B42	PCIE7_TX_DN	A42	GND
B43	GND	A43	PCIE7_RX_DP
B44	GND	A44	PCIE7_RX_DN
B45	PCIE8_TX_DP	A45	GND
B46	PCIE8_TX_DN	A46	GND
B47	GND	A47	PCIE8_RX_DP
B48	N/C	A48	PCIE8_RX_DN
B49	GND	A49	GND
B50	PCIE9_TX_DP	A50	N/C
B51	PCIE9_TX_DN	A51	GND
B52	GND	A52	PCIE9_RX_DP
B53	GND	A53	PCIE9_RX_DN
B54	PCIE10_TX_DP	A54	GND
B55	PCIE10_TX_DN	A55	GND
B56	GND	A56	PCIE10_RX_DP
B57	GND	A57	PCIE10_RX_DN
B58	PCIE11_TX_DP	A58	GND
B59	PCIE11_TX_DN	A59	GND
B60	GND	A60	PCIE11_RX_DP
B61	GND	A61	PCIE11_RX_DN
B62	PCIE12_TX_DP	A62	GND
B63	PCIE12_TX_DN	A63	GND
B64	GND	A64	PCIE12_RX_DP
B65	GND	A65	PCIE12_RX_DN
B66	PCIE13_TX_DP	A66	GND
B67	PCIE13_TX_DN	A67	GND
B68	GND	A68	PCIE13_RX_DP
B69	GND	A69	PCIE13_RX_DN
B70	PCIE14_TX_DP	A70	GND
B71	PCIE14_TX_DN	A71	GND
B72	GND	A72	PCIE14_RX_DP
B73	GND	A73	PCIE14_RX_DN
B74	PCIE15_TX_DP	A74	GND
B75	PCIE15_TX_DN	A75	GND
B76	GND	A76	PCIE15_RX_DP
B77	GND	A77	PCIE15_RX_DN
B78	PCIE16_TX_DP	A78	GND
B79	PCIE16_TX_DN	A79	GND
B80	GND	A80	PCIE16_RX_DP
B81	N/C	A81	PCIE16_RX_DN
B82	N/C	A82	GND

2.4.18 eDP Connector (SCN2)

The embedded DisplayPort (eDP) interface is available through 40-pin connector (SCN2), which is compliant with I-PEX-CABLIN II HT1 20143.

Pin	Signal	Pin	Signal
1	+DVCCM	21	eDP_TXN0
2	+DVCCM	22	eDP_TXP0
3	+DVCCM	23	GND
4	+DVCCM	24	eDP_AUX_DP
5	NC	25	eDP_AUX_DN
6	GND	26	GND
7	GND	27	GND
8	GND	28	GND
9	GND	29	GND
10	eDP_HPD#	30	GND
11	GND	31	NC
12	eDP_TXN3	32	eDP_BLT_CTRL
13	eDP_TXP3	33	eDP_BLT_EN
14	GND	34	NC
15	eDP_TXN2	35	NC
16	eDP_TXP2	36	+12V_EDP_BKLT
17	GND	37	+12V_EDP_BKLT
18	eDP_TXN1	38	+12V_EDP_BKLT
19	eDP_TXP1	39	+12V_EDP_BKLT
20	GND	40	NC

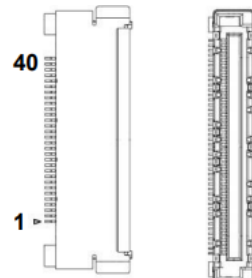

Section 3

Hardware Description

3.1 Microprocessors

The MANO566 Series supports 14th/ 13th/ 12th Generation Intel® Core™ i9/ i7/ i5/ i3 processors and Celeron / Pentium® processor, which enable your system to operate under Windows® 10/ 11 and Linux environments. The system performance depends on the microprocessor. Make sure all correct settings are arranged for your installed microprocessor to prevent the CPU from damages.

3.2 BIOS

The MANO566 Series uses AMI Plug and Play BIOS with a single SPI Flash.

3.3 System Memory

The MANO566 supports two 262-pin DDR5 SO-DIMM sockets for maximum memory capacity up to 96GB DDR5 SDRAMs. The memory module comes in sizes of 8GB,16GB, 32GB, 48GB,64GB and 96GB.

















































Note

- *For single memory channel configuration, install memory module in channel A (DIMM1) DDR5 SO-DIMM socket, maximum 48GB per module.*
- *For dual memory channel configuration, install memory modules of the same size, chip width, density and rank in both channel A (DIMM1) and channel B (DIMM2) DDR5 SO-DIMM sockets, maximum 96GB per module.*















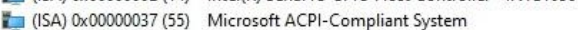





















































































3.4 I/O Port Address Map

























































































 Input/output (IO)

	[0000000000000000 - 000000000000CF7]	PCI Express Root Complex
	[0000000000000020 - 0000000000000021]	Programmable interrupt controller
	[0000000000000024 - 0000000000000025]	Programmable interrupt controller
	[0000000000000028 - 0000000000000029]	Programmable interrupt controller
	[000000000000002C - 000000000000002D]	Programmable interrupt controller
	[000000000000002E - 000000000000002F]	Motherboard resources
	[0000000000000030 - 0000000000000031]	Programmable interrupt controller
	[0000000000000034 - 0000000000000035]	Programmable interrupt controller
	[0000000000000038 - 0000000000000039]	Programmable interrupt controller
	[000000000000003C - 000000000000003D]	Programmable interrupt controller
	[0000000000000040 - 0000000000000043]	System timer
	[000000000000004E - 000000000000004F]	Motherboard resources
	[0000000000000050 - 0000000000000053]	System timer
	[0000000000000061 - 0000000000000061]	Motherboard resources
	[0000000000000063 - 0000000000000063]	Motherboard resources
	[0000000000000065 - 0000000000000065]	Motherboard resources
	[0000000000000067 - 0000000000000067]	Motherboard resources
	[0000000000000070 - 0000000000000070]	Motherboard resources
	[0000000000000080 - 0000000000000080]	Motherboard resources
	[0000000000000092 - 0000000000000092]	Motherboard resources
	[00000000000000A0 - 00000000000000A1]	Programmable interrupt controller
	[00000000000000A4 - 00000000000000A5]	Programmable interrupt controller
	[00000000000000A8 - 00000000000000A9]	Programmable interrupt controller
	[00000000000000AC - 00000000000000AD]	Programmable interrupt controller
	[00000000000000B0 - 00000000000000B1]	Programmable interrupt controller
	[00000000000000B2 - 00000000000000B3]	Motherboard resources
	[00000000000000B4 - 00000000000000B5]	Programmable interrupt controller
	[00000000000000B8 - 00000000000000B9]	Programmable interrupt controller
	[00000000000000BC - 00000000000000BD]	Programmable interrupt controller
	[00000000000002E8 - 00000000000002EF]	Communications Port (COM4)
	[00000000000002F8 - 00000000000002FF]	Communications Port (COM2)
	[00000000000003E8 - 00000000000003EF]	Communications Port (COM3)
	[00000000000003F8 - 00000000000003FF]	Communications Port (COM1)
	[00000000000004D0 - 00000000000004D1]	Programmable interrupt controller
	[0000000000000680 - 000000000000069F]	Motherboard resources
	[0000000000000A00 - 0000000000000A0F]	Motherboard resources
	[0000000000000A10 - 0000000000000A1F]	Motherboard resources
	[0000000000000A20 - 0000000000000A2F]	Motherboard resources
	[0000000000000D00 - 000000000000FFFF]	PCI Express Root Complex
	[000000000000164E - 000000000000164F]	Motherboard resources
	[0000000000001854 - 0000000000001857]	Motherboard resources
	[0000000000002000 - 00000000000020FE]	Motherboard resources
	[0000000000003000 - 000000000000303F]	Intel(R) UHD Graphics 770
	[0000000000003060 - 000000000000307F]	Standard SATA AHCI Controller
	[0000000000003080 - 0000000000003083]	Standard SATA AHCI Controller
	[0000000000003090 - 0000000000003097]	Standard SATA AHCI Controller
	[000000000000EFA0 - 000000000000EFBF]	Intel(R) SMBus - 7AA3

3.5 Interrupt Controller (IRQ) Map

The interrupt controller (IRQ) mapping list is shown as follows:

Interrupt request (IRQ)	
 (ISA) 0x00000000 (00)	System timer
 (ISA) 0x00000003 (03)	Communications Port (COM2)
 (ISA) 0x00000004 (04)	Communications Port (COM1)
 (ISA) 0x00000005 (05)	Communications Port (COM3)
 (ISA) 0x00000006 (06)	Communications Port (COM4)
 (ISA) 0x0000000E (14)	Intel(R) Serial IO GPIO Host Controller - INTC1056
 (ISA) 0x00000037 (55)	Microsoft ACPI-Compliant System
 (ISA) 0x00000038 (56)	Microsoft ACPI-Compliant System
 (ISA) 0x00000039 (57)	Microsoft ACPI-Compliant System
 (ISA) 0x0000003A (58)	Microsoft ACPI-Compliant System
 (ISA) 0x0000003B (59)	Microsoft ACPI-Compliant System
 (ISA) 0x0000003C (60)	Microsoft ACPI-Compliant System
 (ISA) 0x0000003D (61)	Microsoft ACPI-Compliant System
 (ISA) 0x0000003E (62)	Microsoft ACPI-Compliant System
 (ISA) 0x0000003F (63)	Microsoft ACPI-Compliant System
 (ISA) 0x00000040 (64)	Microsoft ACPI-Compliant System
 (ISA) 0x00000041 (65)	Microsoft ACPI-Compliant System
 (ISA) 0x00000042 (66)	Microsoft ACPI-Compliant System
 (ISA) 0x00000043 (67)	Microsoft ACPI-Compliant System
 (ISA) 0x00000044 (68)	Microsoft ACPI-Compliant System
 (ISA) 0x00000045 (69)	Microsoft ACPI-Compliant System
 (ISA) 0x00000046 (70)	Microsoft ACPI-Compliant System
 (ISA) 0x00000047 (71)	Microsoft ACPI-Compliant System
 (ISA) 0x00000048 (72)	Microsoft ACPI-Compliant System
 (ISA) 0x00000049 (73)	Microsoft ACPI-Compliant System
 (ISA) 0x0000004A (74)	Microsoft ACPI-Compliant System
 (ISA) 0x0000004B (75)	Microsoft ACPI-Compliant System
 (ISA) 0x0000004C (76)	Microsoft ACPI-Compliant System
 (ISA) 0x0000004D (77)	Microsoft ACPI-Compliant System
 (ISA) 0x0000004E (78)	Microsoft ACPI-Compliant System
 (ISA) 0x0000004F (79)	Microsoft ACPI-Compliant System
 (ISA) 0x00000050 (80)	Microsoft ACPI-Compliant System
 (ISA) 0x00000051 (81)	Microsoft ACPI-Compliant System
 (ISA) 0x00000052 (82)	Microsoft ACPI-Compliant System
 (ISA) 0x00000053 (83)	Microsoft ACPI-Compliant System
 (ISA) 0x00000054 (84)	Microsoft ACPI-Compliant System
 (ISA) 0x00000055 (85)	Microsoft ACPI-Compliant System
 (ISA) 0x00000056 (86)	Microsoft ACPI-Compliant System
 (ISA) 0x00000057 (87)	Microsoft ACPI-Compliant System
 (ISA) 0x00000058 (88)	Microsoft ACPI-Compliant System
 (ISA) 0x00000059 (89)	Microsoft ACPI-Compliant System
 (ISA) 0x0000005A (90)	Microsoft ACPI-Compliant System
 (ISA) 0x0000005B (91)	Microsoft ACPI-Compliant System
 (ISA) 0x0000005C (92)	Microsoft ACPI-Compliant System
 (ISA) 0x0000005D (93)	Microsoft ACPI-Compliant System
 (ISA) 0x0000005E (94)	Microsoft ACPI-Compliant System
 (ISA) 0x0000005F (95)	Microsoft ACPI-Compliant System
 (ISA) 0x00000060 (96)	Microsoft ACPI-Compliant System
 (ISA) 0x00000061 (97)	Microsoft ACPI-Compliant System
 (ISA) 0x00000062 (98)	Microsoft ACPI-Compliant System
 (ISA) 0x00000063 (99)	Microsoft ACPI-Compliant System
 (ISA) 0x00000064 (100)	Microsoft ACPI-Compliant System
 (ISA) 0x00000065 (101)	Microsoft ACPI-Compliant System
 (ISA) 0x00000066 (102)	Microsoft ACPI-Compliant System
 (ISA) 0x00000067 (103)	Microsoft ACPI-Compliant System
 (ISA) 0x00000068 (104)	Microsoft ACPI-Compliant System
 (ISA) 0x00000069 (105)	Microsoft ACPI-Compliant System
 (ISA) 0x0000006A (106)	Microsoft ACPI-Compliant System
 (ISA) 0x0000006B (107)	Microsoft ACPI-Compliant System
 (ISA) 0x0000006C (108)	Microsoft ACPI-Compliant System
 (ISA) 0x0000006D (109)	Microsoft ACPI-Compliant System
 (ISA) 0x0000006D (109)	Trusted Platform Module 2.0
 (ISA) 0x0000006E (110)	Microsoft ACPI-Compliant System
 (ISA) 0x0000006F (111)	Microsoft ACPI-Compliant System
 (ISA) 0x00000070 (112)	Microsoft ACPI-Compliant System
 (ISA) 0x00000071 (113)	Microsoft ACPI-Compliant System
 (ISA) 0x00000072 (114)	Microsoft ACPI-Compliant System
 (ISA) 0x00000073 (115)	Microsoft ACPI-Compliant System
 (ISA) 0x00000074 (116)	Microsoft ACPI-Compliant System
 (ISA) 0x00000075 (117)	Microsoft ACPI-Compliant System
 (ISA) 0x00000076 (118)	Microsoft ACPI-Compliant System
 (ISA) 0x00000077 (119)	Microsoft ACPI-Compliant System
 (ISA) 0x00000078 (120)	Microsoft ACPI-Compliant System
 (ISA) 0x00000079 (121)	Microsoft ACPI-Compliant System
 (ISA) 0x0000007A (122)	Microsoft ACPI-Compliant System
 (ISA) 0x0000007B (123)	Microsoft ACPI-Compliant System
 (ISA) 0x0000007C (124)	Microsoft ACPI-Compliant System
 (ISA) 0x0000007D (125)	Microsoft ACPI-Compliant System
 (ISA) 0x0000007E (126)	Microsoft ACPI-Compliant System
 (ISA) 0x0000007F (127)	Microsoft ACPI-Compliant System
 (ISA) 0x00000080 (128)	Microsoft ACPI-Compliant System
 (ISA) 0x00000081 (129)	Microsoft ACPI-Compliant System
 (ISA) 0x00000082 (130)	Microsoft ACPI-Compliant System
 (ISA) 0x00000083 (131)	Microsoft ACPI-Compliant System
 (ISA) 0x00000084 (132)	Microsoft ACPI-Compliant System
 (ISA) 0x00000085 (133)	Microsoft ACPI-Compliant System
 (ISA) 0x00000086 (134)	Microsoft ACPI-Compliant System
 (ISA) 0x00000087 (135)	Microsoft ACPI-Compliant System
 (ISA) 0x00000088 (136)	Microsoft ACPI-Compliant System
 (ISA) 0x00000089 (137)	Microsoft ACPI-Compliant System
 (ISA) 0x0000008A (138)	Microsoft ACPI-Compliant System
 (ISA) 0x0000008B (139)	Microsoft ACPI-Compliant System
 (ISA) 0x0000008C (140)	Microsoft ACPI-Compliant System
 (ISA) 0x0000008D (141)	Microsoft ACPI-Compliant System
 (ISA) 0x0000008E (142)	Microsoft ACPI-Compliant System
 (ISA) 0x0000008F (143)	Microsoft ACPI-Compliant System
 (ISA) 0x00000090 (144)	Microsoft ACPI-Compliant System
 (ISA) 0x00000091 (145)	Microsoft ACPI-Compliant System
 (ISA) 0x00000092 (146)	Microsoft ACPI-Compliant System
 (ISA) 0x00000093 (147)	Microsoft ACPI-Compliant System
 (ISA) 0x00000094 (148)	Microsoft ACPI-Compliant System
 (ISA) 0x00000095 (149)	Microsoft ACPI-Compliant System

 (ISA) 0x000001FB (507)	Microsoft ACPI-Compliant System	 (PCI) 0xFFFFFDDA (-38)	Intel(R) Ethernet Controller I226-V #2
 (ISA) 0x000001FC (508)	Microsoft ACPI-Compliant System	 (PCI) 0xFFFFFDDB (-37)	Intel(R) Ethernet Controller I226-V #2
 (ISA) 0x000001FD (509)	Microsoft ACPI-Compliant System	 (PCI) 0xFFFFFDDC (-36)	Intel(R) Ethernet Controller I226-V #2
 (ISA) 0x000001FE (510)	Microsoft ACPI-Compliant System	 (PCI) 0xFFFFFDDD (-35)	Intel(R) Ethernet Controller I226-V #2
 (ISA) 0x000001FF (511)	Microsoft ACPI-Compliant System	 (PCI) 0xFFFFFDE (-34)	Intel(R) Ethernet Controller I226-V #2
 (PCI) 0x00000010 (16)	Intel(R) Serial IO UART Host Controller - 7AA8	 (PCI) 0xFFFFFDDF (-33)	Intel(R) Ethernet Controller I226-V #2
 (PCI) 0x00000011 (17)	High Definition Audio Controller	 (PCI) 0xFFFFFEE0 (-32)	Intel(R) Ethernet Controller I226-V #2
 (PCI) 0x0000001B (27)	Intel(R) Serial IO I2C Host Controller - 7ACC	 (PCI) 0xFFFFFEE1 (-31)	Intel(R) Ethernet Controller I226-V #2
 (PCI) 0x0000001D (29)	Intel(R) Serial IO I2C Host Controller - 7ACE	 (PCI) 0xFFFFFEE2 (-30)	Intel(R) Ethernet Controller I226-V #2
 (PCI) 0x0000001F (31)	Intel(R) Serial IO I2C Host Controller - 7AFC	 (PCI) 0xFFFFFEE3 (-29)	Intel(R) Ethernet Controller I226-V #2
 (PCI) 0x00000020 (32)	Intel(R) Serial IO I2C Host Controller - 7AFD	 (PCI) 0xFFFFFEE4 (-28)	Intel(R) Ethernet Controller I226-V #2
 (PCI) 0x00000025 (37)	Intel(R) Serial IO SPI Host Controller - 7AAB	 (PCI) 0xFFFFFEE5 (-27)	Intel(R) Ethernet Controller I226-V #2
 (PCI) 0x00000028 (40)	Intel(R) Serial IO I2C Host Controller - 7ACD	 (PCI) 0xFFFFFEE6 (-26)	Intel(R) Ethernet Controller I226-V #2
 (PCI) 0x0000002B (43)	Intel(R) Serial IO I2C Host Controller - 7ACF	 (PCI) 0xFFFFFEE7 (-25)	Intel(R) Ethernet Controller I226-V #2
 (PCI) 0xFFFFF7B (-75)	Intel(R) Management Engine Interface #1	 (PCI) 0xFFFFFEE8 (-24)	Intel(R) Ethernet Controller I226-V #2
 (PCI) 0xFFFFF7B6 (-74)	Intel(R) GNA Scoring Accelerator module	 (PCI) 0xFFFFFEE9 (-23)	Intel(R) USB 3.20 eXtensible Host Controller - 1.20 (Microsoft)
 (PCI) 0xFFFFF7B7 (-73)	Intel(R) Ethernet Controller I226-V	 (PCI) 0xFFFFFEEA (-22)	Intel(R) UHD Graphics 770
 (PCI) 0xFFFFF7B8 (-72)	Intel(R) Ethernet Controller I226-V	 (PCI) 0xFFFFFEEB (-21)	Standard NVM Express Controller
 (PCI) 0xFFFFF7B9 (-71)	Intel(R) Ethernet Controller I226-V	 (PCI) 0xFFFFFEFC (-20)	Standard NVM Express Controller
 (PCI) 0xFFFFF7BA (-70)	Intel(R) Ethernet Controller I226-V	 (PCI) 0xFFFFFEFD (-19)	Standard NVM Express Controller
 (PCI) 0xFFFFF7BB (-69)	Intel(R) Ethernet Controller I226-V	 (PCI) 0xFFFFFEFE (-18)	Standard NVM Express Controller
 (PCI) 0xFFFFF7BC (-68)	Intel(R) Ethernet Controller I226-V	 (PCI) 0xFFFFFEFF (-17)	Standard NVM Express Controller
 (PCI) 0xFFFFF7BD (-67)	Intel(R) Ethernet Controller I226-V	 (PCI) 0xFFFFFFF0 (-16)	Standard NVM Express Controller
 (PCI) 0xFFFFF7BE (-66)	Intel(R) Ethernet Controller I226-V	 (PCI) 0xFFFFFFF1 (-15)	Standard NVM Express Controller
 (PCI) 0xFFFFF7BF (-65)	Intel(R) Ethernet Controller I226-V	 (PCI) 0xFFFFFFF2 (-14)	Standard NVM Express Controller
 (PCI) 0xFFFFF7C0 (-64)	Intel(R) Ethernet Controller I226-V	 (PCI) 0xFFFFFFF3 (-13)	Standard NVM Express Controller
 (PCI) 0xFFFFF7C1 (-63)	Intel(R) Ethernet Controller I226-V	 (PCI) 0xFFFFFFF4 (-12)	Standard NVM Express Controller
 (PCI) 0xFFFFF7C2 (-62)	Intel(R) Ethernet Controller I226-V	 (PCI) 0xFFFFFFF5 (-11)	Standard NVM Express Controller
 (PCI) 0xFFFFF7C3 (-61)	Intel(R) Ethernet Controller I226-V	 (PCI) 0xFFFFFFF6 (-10)	Standard NVM Express Controller
 (PCI) 0xFFFFF7C4 (-60)	Intel(R) Ethernet Controller I226-V	 (PCI) 0xFFFFFFF7 (-9)	Standard NVM Express Controller
 (PCI) 0xFFFFF7C5 (-59)	Intel(R) Ethernet Controller I226-V	 (PCI) 0xFFFFFFF8 (-8)	Standard NVM Express Controller
 (PCI) 0xFFFFF7C6 (-58)	Intel(R) Ethernet Controller I226-V	 (PCI) 0xFFFFFFF9 (-7)	Standard NVM Express Controller
 (PCI) 0xFFFFF7C7 (-57)	Intel(R) Ethernet Controller I226-V	 (PCI) 0xFFFFFFFA (-6)	Standard NVM Express Controller
 (PCI) 0xFFFFF7C8 (-56)	Intel(R) Ethernet Controller I226-V	 (PCI) 0xFFFFFFFB (-5)	Standard SATA AHCI Controller
 (PCI) 0xFFFFF7C9 (-55)	Intel(R) Ethernet Controller I226-V	 (PCI) 0xFFFFFFFC (-4)	Intel(R) PCI Express Root Port #5 - 7AB5
 (PCI) 0xFFFFF7CA (-54)	Intel(R) Ethernet Controller I226-V	 (PCI) 0xFFFFFFFD (-3)	Intel(R) PCI Express Root Port #3 - 7ABA
 (PCI) 0xFFFFF7CB (-53)	Intel(R) Ethernet Controller I226-V	 (PCI) 0xFFFFFFFE (-2)	Intel(R) PCI Express Root Port #2 - 7AB9
 (PCI) 0xFFFFF7CC (-52)	Intel(R) Ethernet Controller I226-V		
 (PCI) 0xFFFFF7CD (-51)	Intel(R) Ethernet Controller I226-V		
 (PCI) 0xFFFFF7CE (-50)	Intel(R) Ethernet Controller I226-V		
 (PCI) 0xFFFFF7CF (-49)	Intel(R) Ethernet Controller I226-V		
 (PCI) 0xFFFFF7D0 (-48)	Intel(R) Ethernet Controller I226-V #2		
 (PCI) 0xFFFFF7D1 (-47)	Intel(R) Ethernet Controller I226-V #2		
 (PCI) 0xFFFFF7D2 (-46)	Intel(R) Ethernet Controller I226-V #2		
 (PCI) 0xFFFFF7D3 (-45)	Intel(R) Ethernet Controller I226-V #2		
 (PCI) 0xFFFFF7D4 (-44)	Intel(R) Ethernet Controller I226-V #2		
 (PCI) 0xFFFFF7D5 (-43)	Intel(R) Ethernet Controller I226-V #2		
 (PCI) 0xFFFFF7D6 (-42)	Intel(R) Ethernet Controller I226-V #2		
 (PCI) 0xFFFFF7D7 (-41)	Intel(R) Ethernet Controller I226-V #2		
 (PCI) 0xFFFFF7D8 (-40)	Intel(R) Ethernet Controller I226-V #2		
 (PCI) 0xFFFFF7D9 (-39)	Intel(R) Ethernet Controller I226-V #2		

3.6 Memory Map

Memory	
[0000000000A0000 - 0000000000BFFFFF]	PCI Express Root Complex
[0000000000E0000 - 0000000000E3FFFF]	PCI Express Root Complex
[0000000000E4000 - 0000000000E7FFFF]	PCI Express Root Complex
[0000000000E8000 - 0000000000EBFFFF]	PCI Express Root Complex
[0000000000EC000 - 0000000000EFFFFF]	PCI Express Root Complex
[0000000000F0000 - 0000000000FFFFFF]	PCI Express Root Complex
[000000080400000 - 0000000806FFFFF]	Intel(R) PCI Express Root Port #3 - 7ABA
[000000080400000 - 0000000BFFFFFFF]	PCI Express Root Complex
[000000080500000 - 0000000805FFFFF]	Intel(R) Ethernet Controller I226-V #2
[000000080600000 - 000000080603FFF]	Intel(R) Ethernet Controller I226-V #2
[000000080700000 - 0000000809FFFFF]	Intel(R) PCI Express Root Port #2 - 7AB9
[000000080800000 - 0000000808FFFFF]	Intel(R) Ethernet Controller I226-V
[000000080900000 - 000000080903FFF]	Intel(R) Ethernet Controller I226-V
[000000080A00000 - 000000080A03FFF]	Standard NVM Express Controller
[000000080A00000 - 000000080AFFFFF]	Intel(R) PCI Express Root Port #5 - 7ABC
[000000080B00000 - 000000080B01FFF]	Standard SATA AHCI Controller
[000000080B02000 - 000000080B027FF]	Standard SATA AHCI Controller
[000000080B03000 - 000000080B030FF]	Standard SATA AHCI Controller
[0000000C0000000 - 0000000CFFFFFFF]	Motherboard resources
[0000000E0690000 - 0000000E069FFFFF]	Intel(R) Serial IO GPIO Host Controller - INTC1056
[0000000E06A0000 - 0000000E06AFFFFF]	Intel(R) Serial IO GPIO Host Controller - INTC1056
[0000000E06B0000 - 0000000E06BFFFFF]	Intel(R) Serial IO GPIO Host Controller - INTC1056
[0000000E06D0000 - 0000000E06DFFFFF]	Intel(R) Serial IO GPIO Host Controller - INTC1056
[0000000E06E0000 - 0000000E06EFFFFF]	Intel(R) Serial IO GPIO Host Controller - INTC1056
[0000000FE001210 - 0000000FE001247]	Intel(R) Time-Aware GPIO device - 1023
[0000000FE001310 - 0000000FE001347]	Intel(R) Time-Aware GPIO device - 1024
[0000000FE010000 - 0000000FE010FFF]	Intel(R) SPI (flash) Controller - 7AA4
[0000000FED00000 - 0000000FED003FF]	High precision event timer
[0000000FED20000 - 0000000FED7FFFFF]	Motherboard resources
[0000000FED40000 - 0000000FED44FFF]	Trusted Platform Module 2.0
[0000000FED45000 - 0000000FED8FFFFF]	Motherboard resources
[0000000FED90000 - 0000000FED93FFF]	Motherboard resources
[0000000FEDA0000 - 0000000FEDA0FFF]	Motherboard resources
[0000000FEDA1000 - 0000000FEDA1FFF]	Motherboard resources
[0000000FEDC0000 - 0000000FEDC7FFF]	Motherboard resources
[0000000FEE00000 - 0000000FEEFFFFFFF]	Motherboard resources
[0000004000000000 - 00000040FFFFFFF]	Intel(R) UHD Graphics 770
[0000006000000000 - 0000006000FFFFFFF]	Intel(R) UHD Graphics 770
[0000006001120000 - 000000600112FFFFF]	Intel(R) USB 3.20 eXtensible Host Controller - 1.20 (Microsoft)
[0000006001130000 - 0000006001137FFF]	Intel(R) Crashlog - A77D
[0000006001148000 - 00000060011480FF]	Intel(R) SMBus - 7AA3
[0000007FFFEF2000 - 0000007FFFEF2FFF]	Intel(R) Serial IO UART Host Controller - 7AA8
[0000007FFFEF3000 - 0000007FFFEF3FFF]	Intel(R) Serial IO I2C Host Controller - 7AFD
[0000007FFFEF4000 - 0000007FFFEF4FFF]	Intel(R) Serial IO I2C Host Controller - 7AFC
[0000007FFFEF5000 - 0000007FFFEF5FFF]	Intel(R) Management Engine Interface #1
[0000007FFFEF6000 - 0000007FFFEF6FFF]	Intel(R) Serial IO I2C Host Controller - 7ACF
[0000007FFFEF7000 - 0000007FFFEF7FFF]	Intel(R) Serial IO I2C Host Controller - 7ACE
[0000007FFFEF8000 - 0000007FFFEF8FFF]	Intel(R) Serial IO I2C Host Controller - 7ACD
[0000007FFFEF9000 - 0000007FFFEF9FFF]	Intel(R) Serial IO I2C Host Controller - 7ACC
[0000007FFFEFA000 - 0000007FFFEFAFFF]	Intel(R) Serial IO SPI Host Controller - 7AAB
[0000007FFFEFB000 - 0000007FFFEFBFFF]	Intel(R) GNA Scoring Accelerator module
[0000007FFFEFC000 - 0000007FFFEFCFFF]	High Definition Audio Controller
[0000007FFFEFD0000 - 0000007FFFEFDFFFFF]	High Definition Audio Controller

Section 4

AMI BIOS Setup Utility

The AMI UEFI BIOS provides users with a built-in setup program to modify basic system configuration. All configured parameters are stored in a flash chip to save the setup information whenever the power is turned off. This chapter provides users with detailed description about how to set up basic system configuration through the AMI BIOS setup utility.

4.1 Starting

To enter the setup screens, follow the steps below:

1. Turn on the computer and press during the Power On Self Test (POST) to enter BIOS setup, otherwise, POST will continue with its test routines.
2. Once you enter the BIOS, the main BIOS setup menu displays. You can access the other setup screens from the main BIOS setup menu, such as the Advanced and Chipset menus.



Note

If your computer cannot boot after making and saving system changes with BIOS setup, you can restore BIOS optimal defaults by setting SW1 (see section 2.3.3).

It is strongly recommended that you should avoid changing the chipset's defaults. Both AMI and your system manufacturer have carefully set up these defaults that provide the best performance and reliability.

4.2 Navigation Keys

The BIOS setup/utility uses a key-based navigation system called hot keys. Most of the BIOS setup utility hot keys can be used at any time during the setup navigation process. These keys include <F1>, <F2>, <Enter>, <ESC>, <Arrow> keys, and so on.



Note

Some of the navigation keys differ from one screen to another.

Hot Keys	Description
→← Left/Right	The Left and Right <Arrow> keys allow you to select a setup screen.
↑↓ Up/Down	The Up and Down <Arrow> keys allow you to select a setup screen or sub screen.
Enter	The <Enter> key allows you to display or change the setup option listed for a particular setup item. The <Enter> key can also allow you to display the setup sub screens.
+– Plus/Minus	The Plus and Minus <Arrow> keys allow you to change the field value of a particular setup item.
F1	The <F1> key allows you to display the General Help screen.
F2	The <F2> key allows you to Load Previous Values.
F3	The <F3> key allows you to Load Optimized Defaults.
F4	The <F4> key allows you to save any changes you have made and exit Setup. Press the <F4> key to save your changes.
Esc	The <Esc> key allows you to discard any changes you have made and exit the Setup. Press the <Esc> key to exit the setup without saving your changes.

4.3 Main Menu

When you first enter the setup utility, you will enter the Main setup screen. You can always return to the Main setup screen by selecting the Main tab. System Time/Date can be set up as described below. The Main BIOS setup screen is shown below.

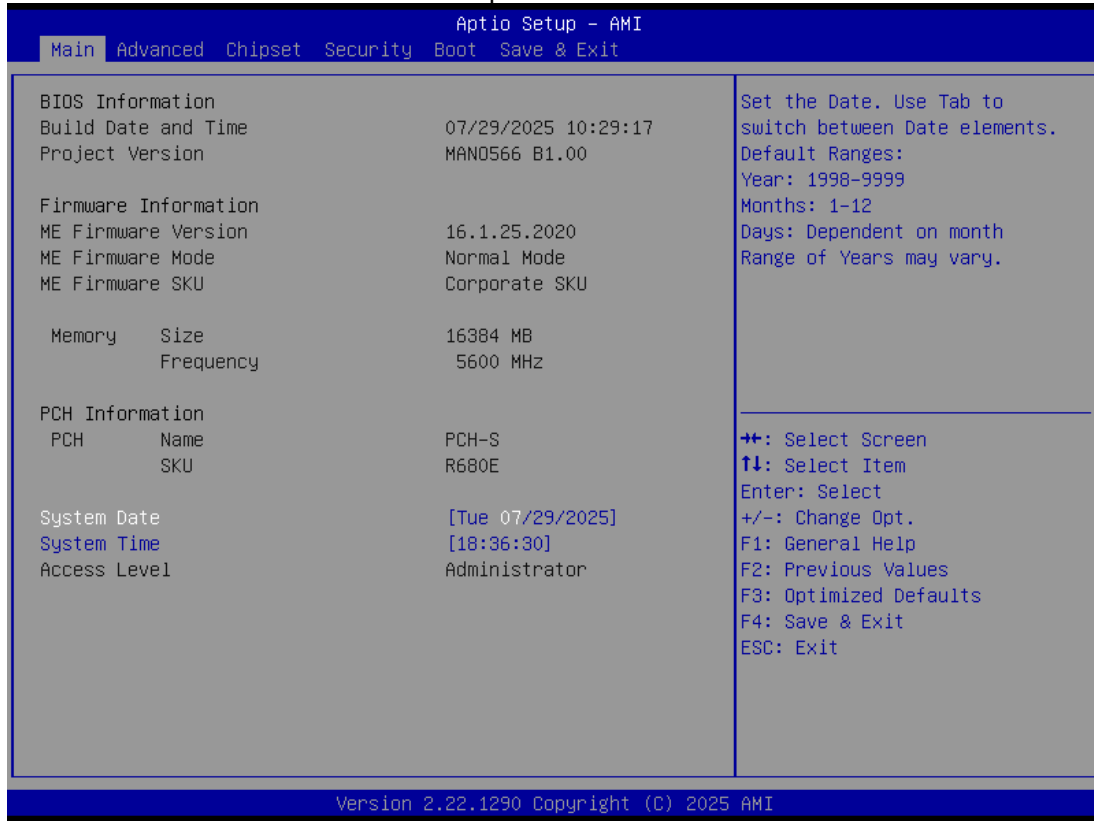

BIOS Information

Display the BIOS information.

Firmware Information

Display the firmware information.

System Date/Time

Use this option to change the system time and date. Highlight System Time or System Date using the <Arrow> keys. Enter new values through the keyboard. Press the <Tab> key or the <Arrow> keys to move between fields. The date must be entered in MM/DD/YY format. The time is entered in HH:MM:SS format.

Access Level

Display the access level of current user.

4.4 Advanced Menu

The Advanced menu also allows users to set configuration of the CPU and other system devices. You can select any of the items in the left frame of the screen to go to the sub menus:

- ▶ ACPI Settings
- ▶ Trusted Computing
- ▶ F81966 DIO Configuration
- ▶ CPU Configuration
- ▶ Storage Configuration
- ▶ NVMe Configuration
- ▶ AMT Configuration
- ▶ F81966 Super IO Configuration
- ▶ Hardware Monitor
- ▶ USB Configuration

For items marked with “▶”, please press <Enter> for more options.

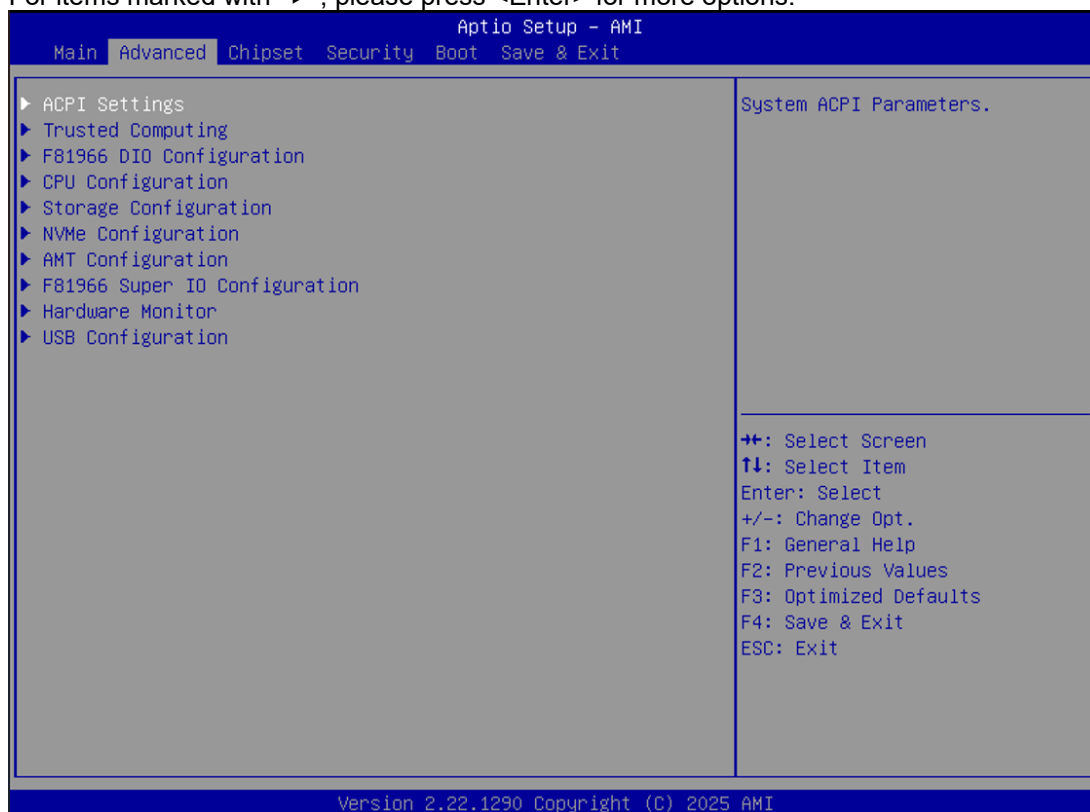

- **F81966 DIO Configuration**

You can use this screen to select options for Digital I/O Configuration.

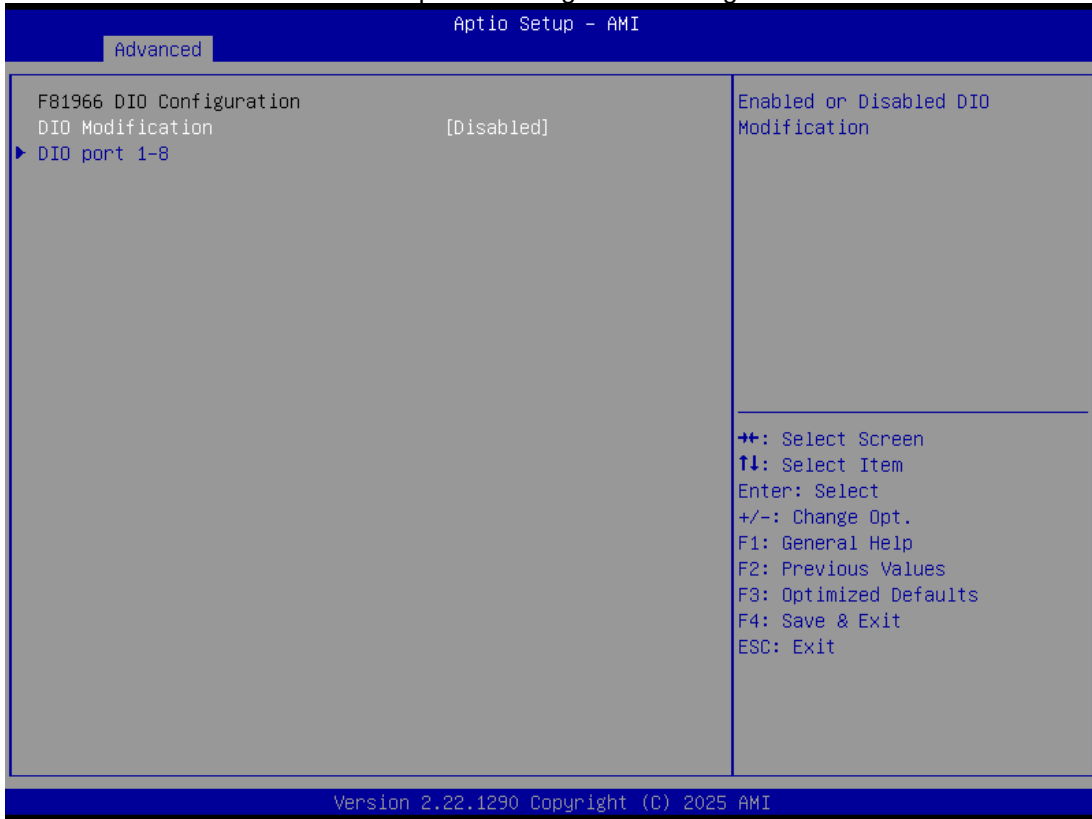

DIO Modification

Enable or disable digital I/O modification. The default is Disabled.

DIO port 1-8

Select this option to open DIO status sub-screen.

If DIO Modification is disabled, you are not allowed to change inputs/outputs setting. The DIO status sub-screen is as follows:

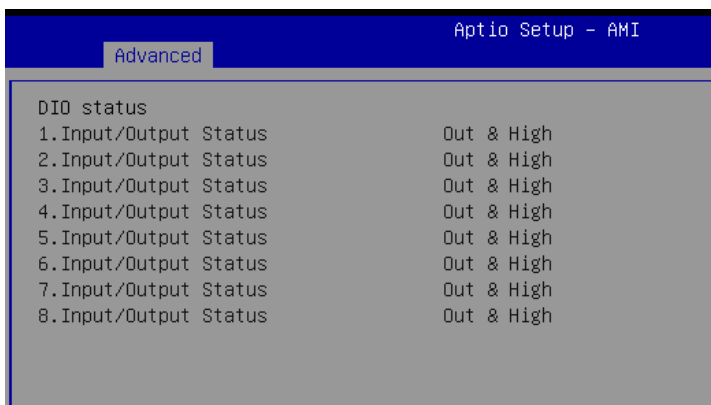

- **CPU Configuration**

This screen shows CPU information, and you can change the value of the selected option.

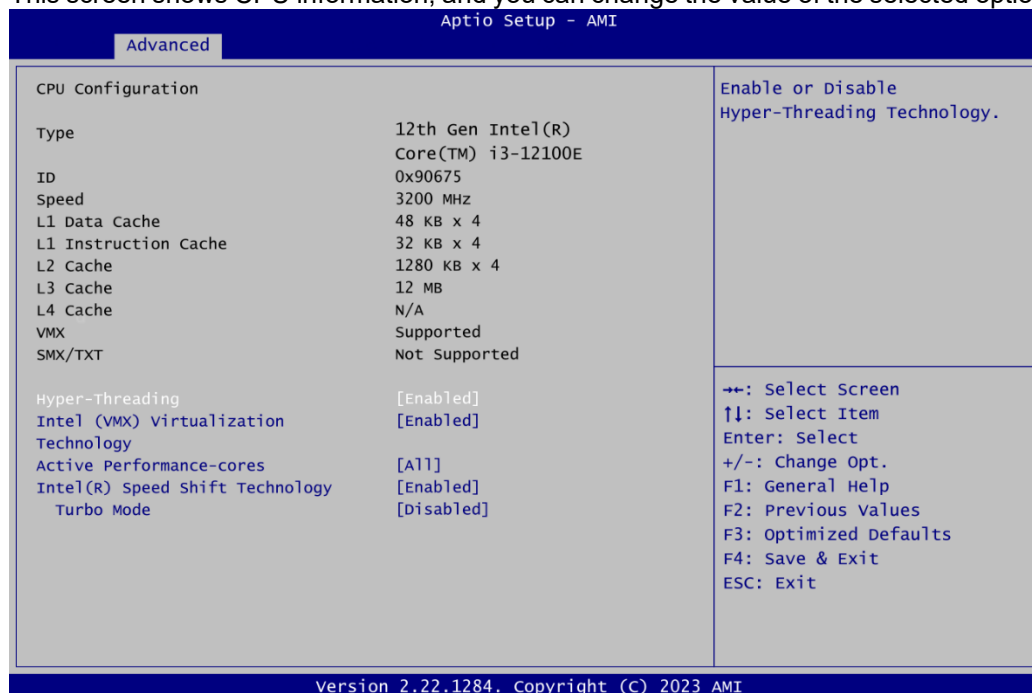

Hyper-Threading

Enable or disable Hyper-Threading Technology. When enabled, it allows a single physical processor to multitask as multiple logical processors. When disabled, only one thread per enabled core is enabled.

Intel (VMX) Virtualization Technology

Enable or disable Intel Virtualization Technology. When enabled, a VMM (Virtual Machine Mode) can utilize the additional hardware capabilities. It allows a platform to run multiple operating systems and applications independently, hence enabling a single computer system to work as several virtual systems.

Active Performance-cores

The number of cores to enable in each processor package.

Intel(R) Speed Shift Technology

Enable or disable Intel® Speed Shift Technology support. Enabling will expose the CPPC v2 interface to allow for hardware controlled P-states.

Turbo Mode

Enable or disable processor Turbo Mode (requires Intel® Speed Shift to be available and enabled).

- **Trusted Computing**

This screen provides function for specifying the TPM (Trusted Platform Module) settings.

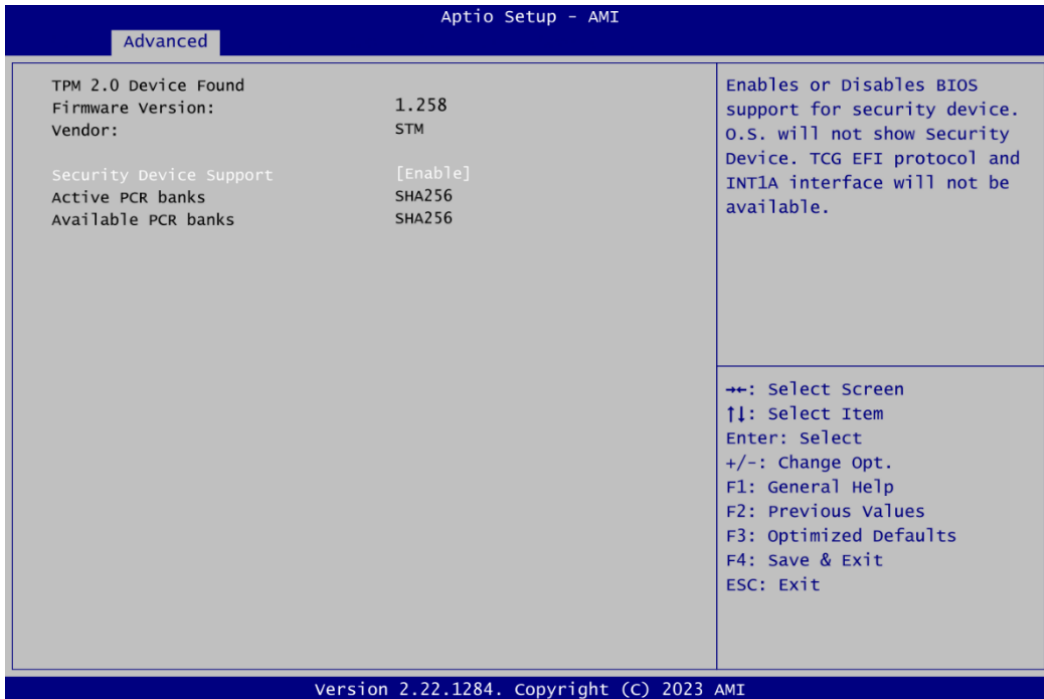

Security Device Support

Enable or disable BIOS support for security device.

-The above screenshot shows the HW TPM support screen. (R680 SKU).

-The below screenshot shows the FW TPM support screen. (Q670E/H610 SKU).

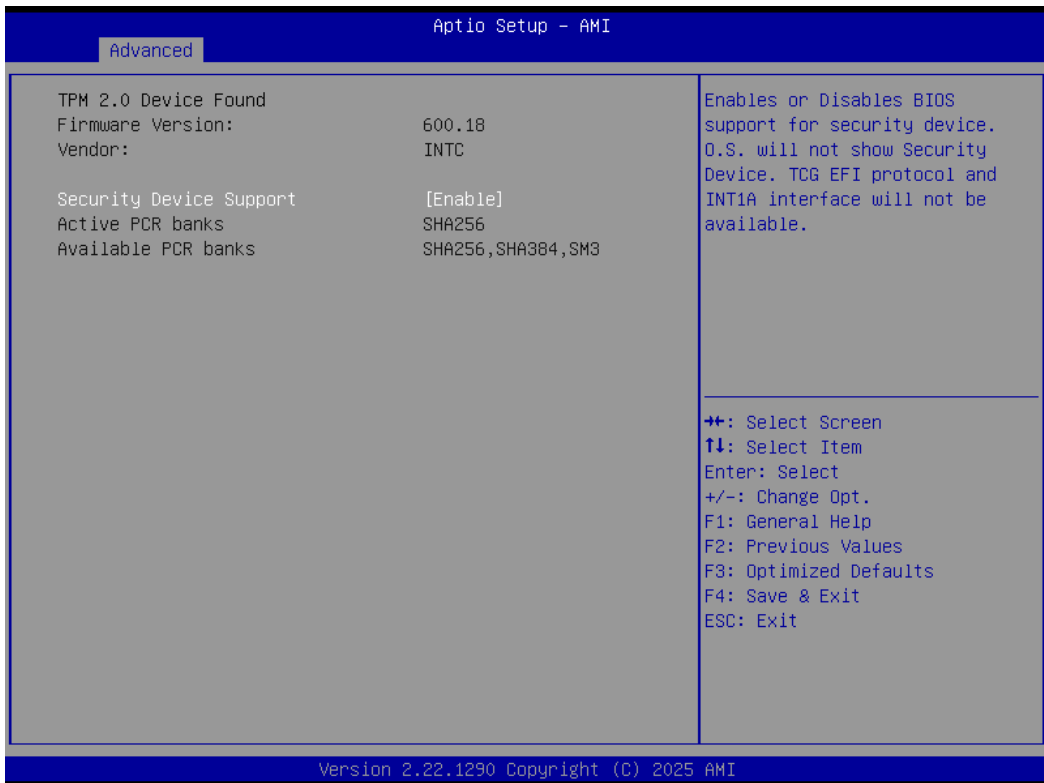

- **ACPI Settings**

You can use this screen to select options for the ACPI configuration, and change the value of the selected option. A description of the selected item appears on the right side of the screen.

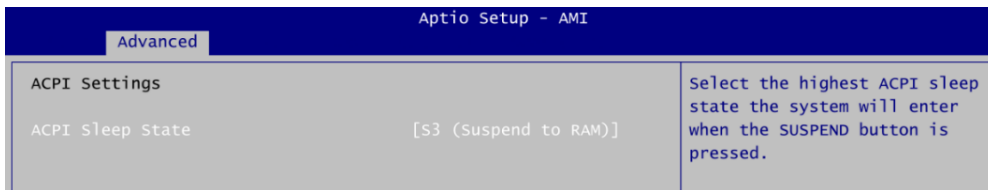

ACPI Sleep State

Select the ACPI (Advanced Configuration and Power Interface) sleep state. The S3 (Suspend to RAM) option selects ACPI sleep state the system will enter when suspend button is pressed.

- **Storage Configuration**

You can use this screen to select options for storage configuration, and change the value of the selected option. A description of the selected item appears on the right side of the screen. For items marked with “▶”, please press <Enter> for more options.

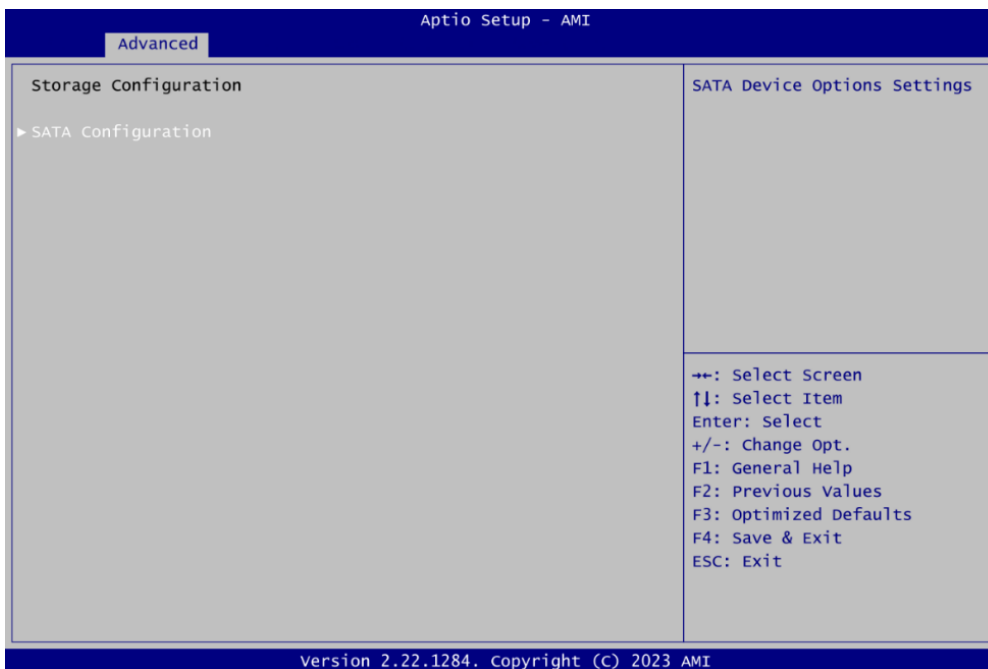

SATA Configuration

During system boot up, BIOS automatically detects the presence of SATA devices. In the SATA configuration menu, you can see hardware currently installed in the SATA port.

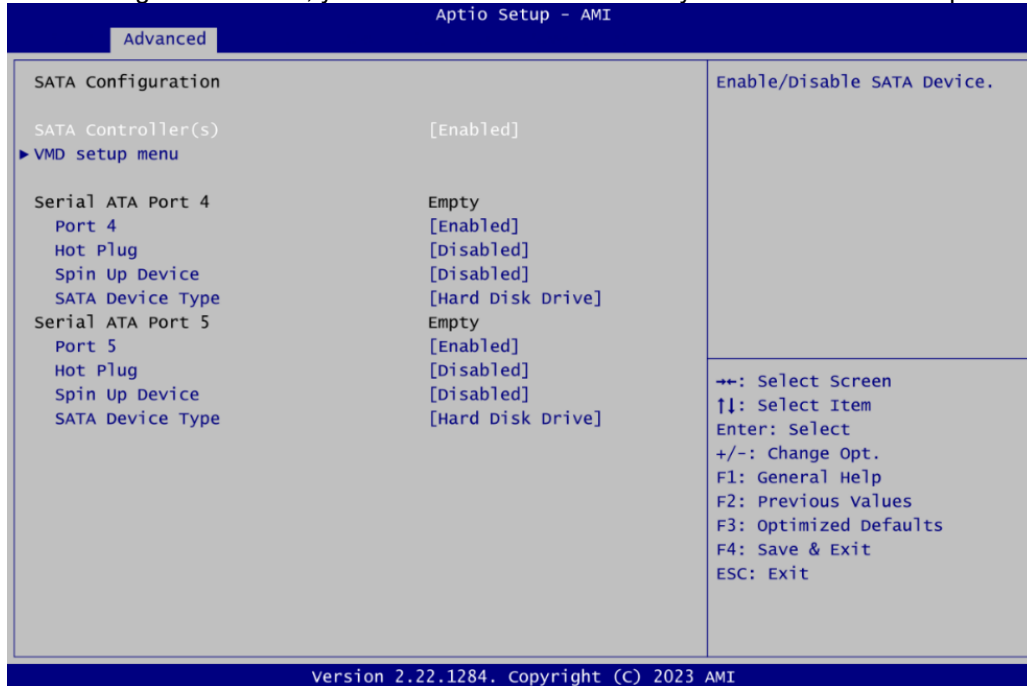

SATA Controller(s)

Enable or disable the SATA Controller feature.

Intel *VMD setup menu

Allows user to configure the VMD controllers.

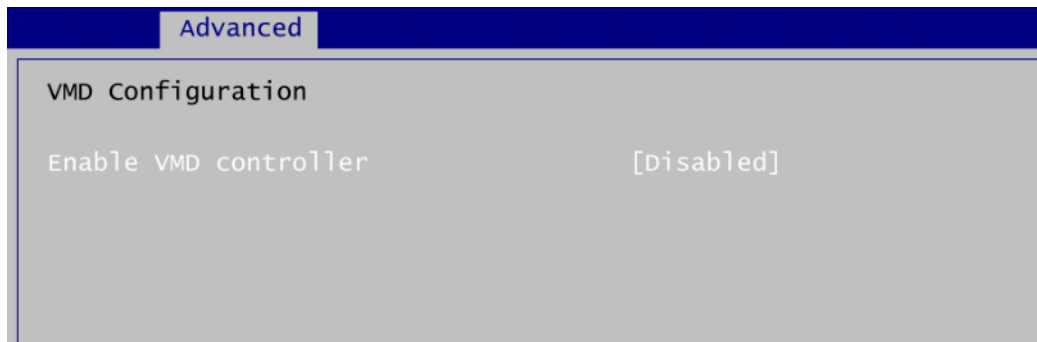

Enable VMD controller

Enable or disable to VMD controller.

*Intel Volume Management Device

- **NVMe Configuration**

This screen displays NVMe (Non-Volatile Memory Express) controller and drive information.

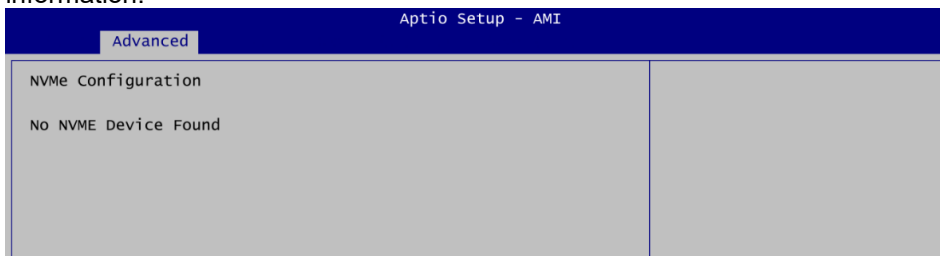

- **F81966 Super IO Configuration**

You can use this screen to select options for the Super IO Configuration, and change the value of the selected option. A description of the selected item appears on the right side of the screen. For items marked with "▶", please press <Enter> for more options.

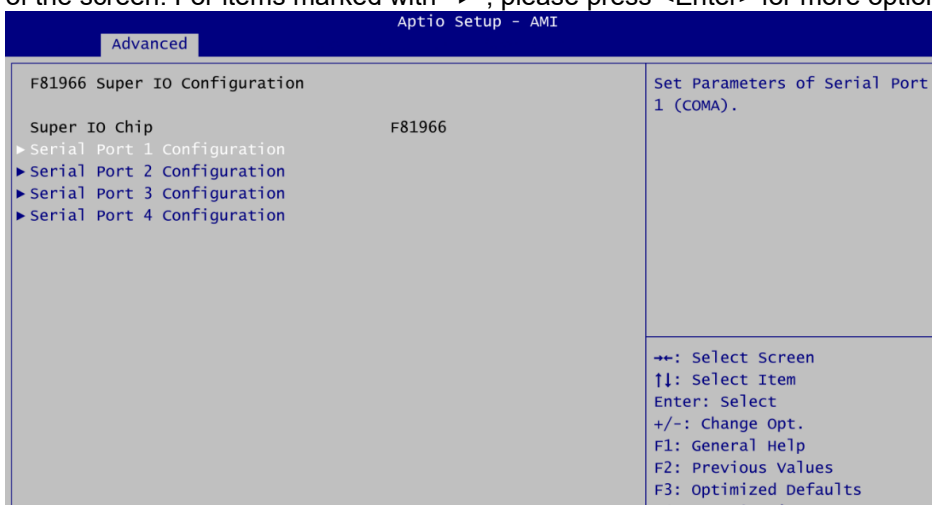

Serial Port 1~4 Configuration

Use these items to set parameters related to serial port 1~4.

- **Serial Port 1 Configuration**

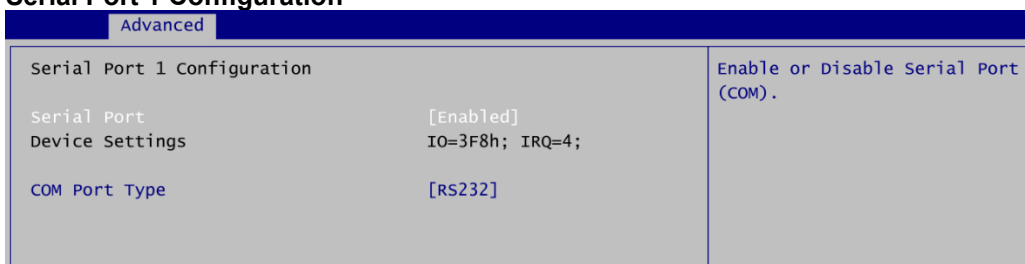

Serial Port

Enable or disable serial port 1. The optimal setting for base I/O address is 3F8h and for interrupt request address is IRQ4.



Note

Serial Port 2~4

The optimal settings for base I/O address and interrupt request address are:

- Serial port 2: 2F8h, IRQ3
- Serial port 3: 3E8h, IRQ5
- Serial port 4: 2E8h, IRQ6

COM Port Type

Use this item to set RS-232/422/485 communication mode.

- **Hardware Monitor**
Monitors hardware health status.

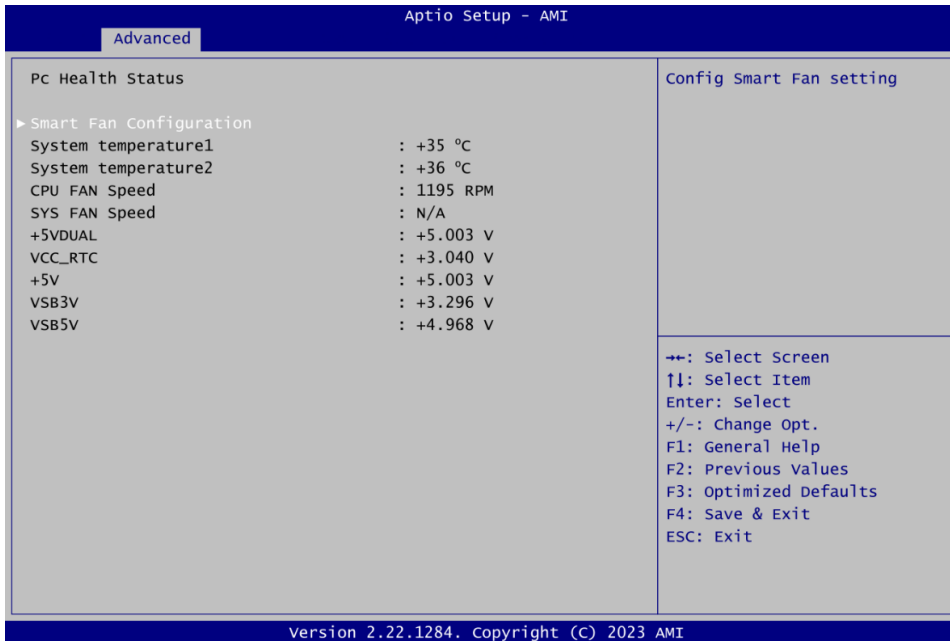

This screen displays the temperature of system, cooling fans speed in RPM and system voltages (+5VDUAL, VCC_RTC, +5V, VSB3V and VSB5V).

- **Smart Fan Configuration**
Allows user to configure CPU fan and system fan mode.

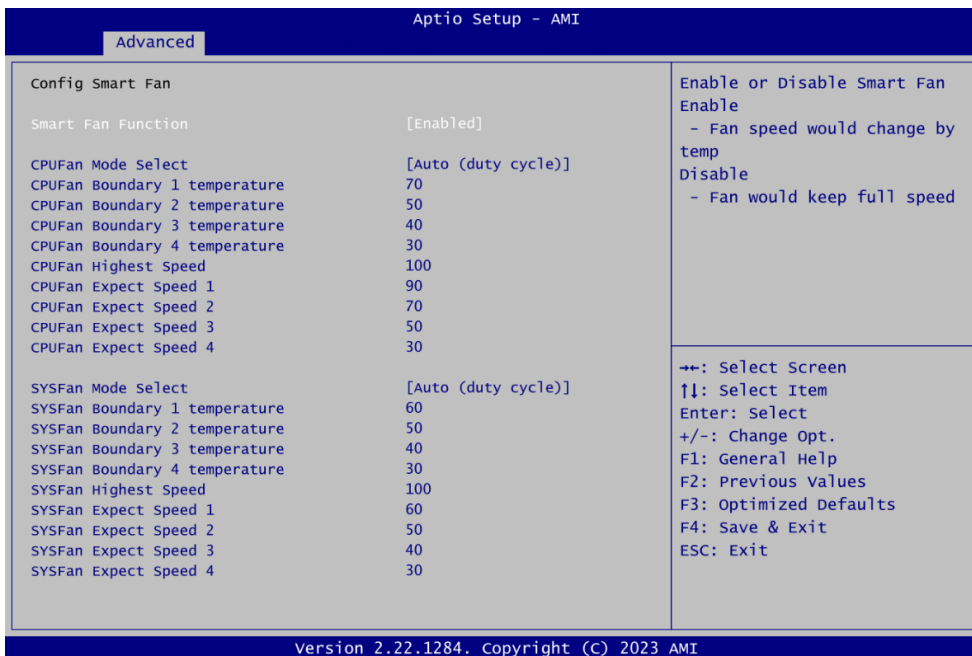

Smart Fan Function

Enable or disable Smart Fan:

- Enable: Fan speed would change according to temperature.
- Disable: The fan always runs at full speed.

- **USB Configuration**

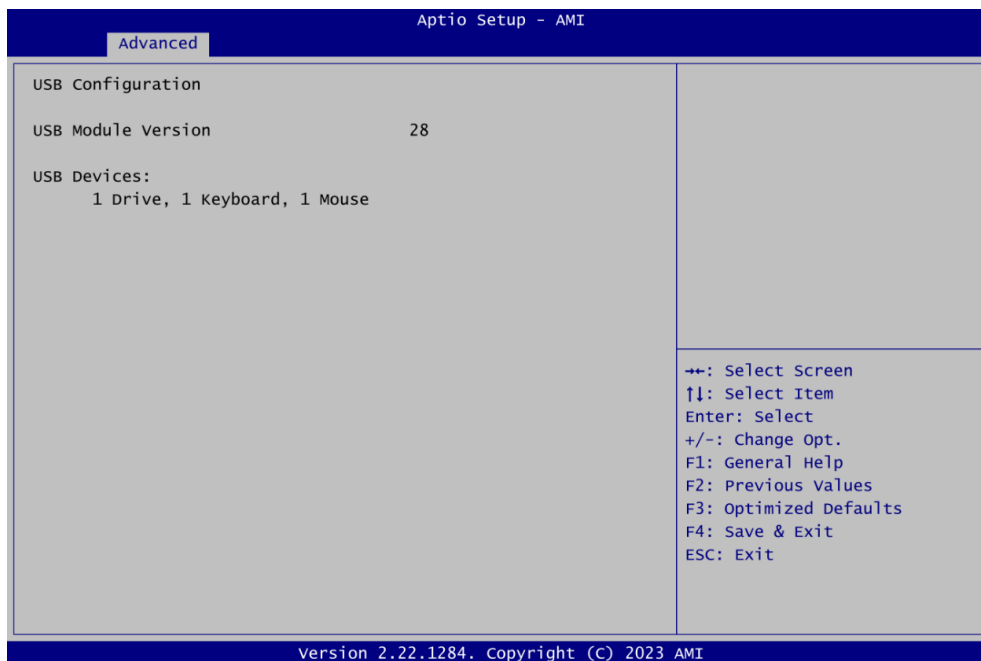

USB Devices

Display all detected USB devices.

- **AMT Configuration**

Use this screen to configure AMT parameters. (Only Supported Q670E & R680E version)

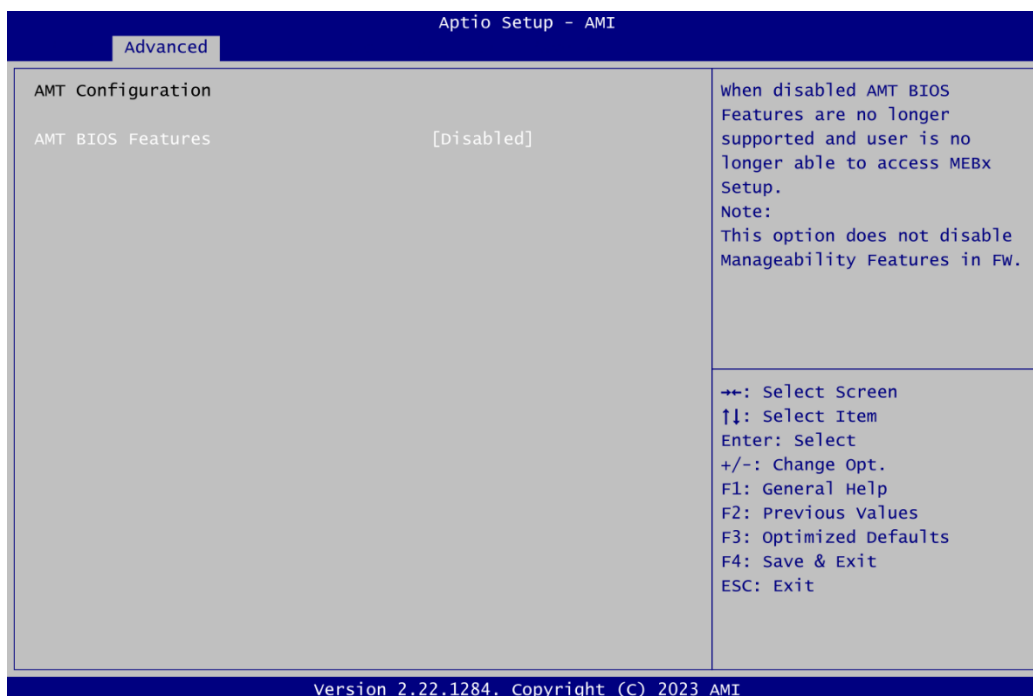

AMT BIOS Features

Enable or disable Active Management Technology BIOS features.

4.5 Chipset Menu

The Chipset menu allows users to change the advanced chipset settings. You can select any of the items in the left frame of the screen to go to the sub menus:

- ▶ System Agent (SA) Configuration
- ▶ PCH-IO Configuration

For items marked with “▶”, please press <Enter> for more options.

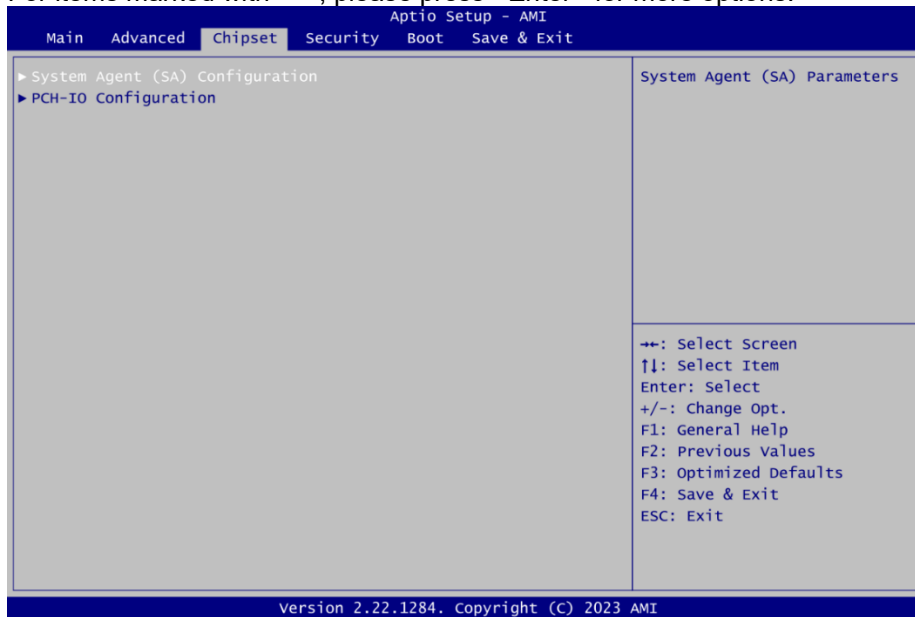

- **System Agent (SA) Configuration**

This screen allows users to configure System Agent (SA) parameters. For items marked with “▶”, please press <Enter> for more options.

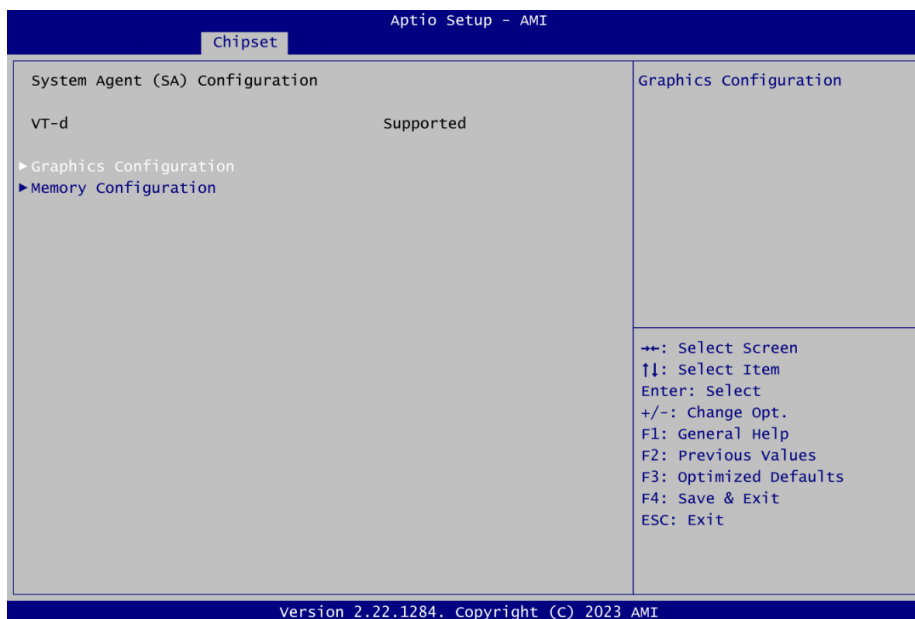

- ▶ **Graphics Configuration**

Open sub menu for parameters related to graphics configuration.

- ▶ **Memory Configuration**

Open sub menu for information related to system memory.

● **Graphics Configuration**



Internal Graphics

Use this item to enable or disable the internal graphics controller. The default Auto setting uses the external graphics card in the PCIe slot as the primary display.

Primary Display

Use this item to select which graphics device (AUTO / IGFX / PEG / PCI / HG) will be used as the primary display, or select HG for Hybrid Graphics.

- **Auto:** The system will automatically select the available graphics device. By default, the external graphics card in the PCIe slot will be used as the primary display if detected.
- **IGFX:** Integrated Graphics. The default output priority is eDP first, followed by DP, and then HDMI.
- **PEG:** PCI Express Graphics. Refers to the external graphics card installed in the x16 PCIe slot (CN24).
- **PCI:** Graphics device connected through the PCH PCIe port, used as the primary display output on the x4 PCIe slot (CN7).
- **HG:** Hybrid Graphics. Allows both the integrated graphics and the external graphics card to work together, enabling hybrid display support.

● **Memory Configuration**

This screen displays the system memory information.

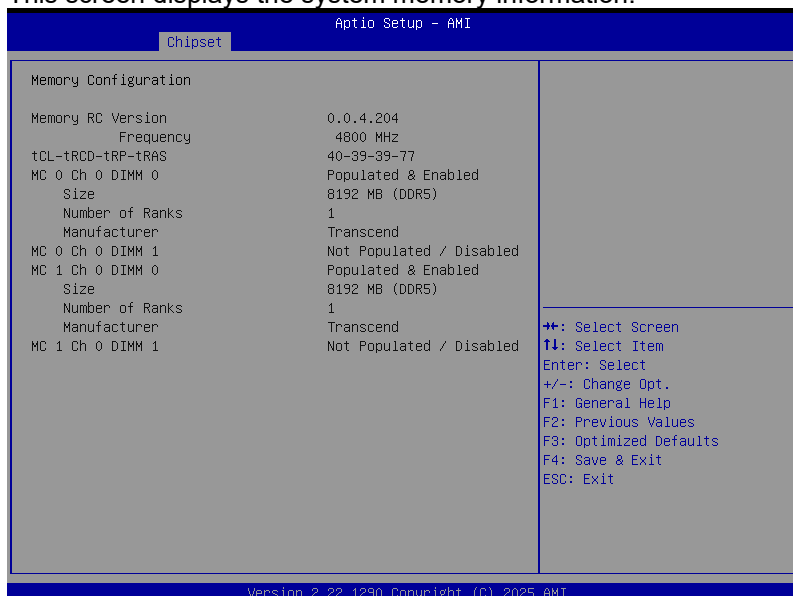

- **PCH-IO Configuration**

This screen allows you to set PCH parameters.



- **PCI Express Configuration**

PCI-Express Configuration settings.

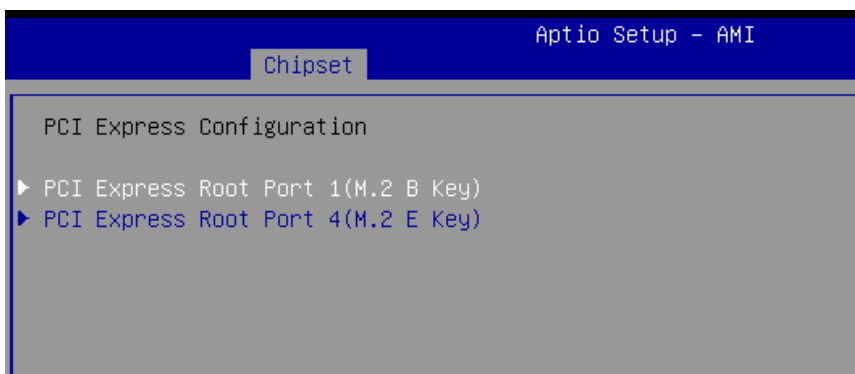
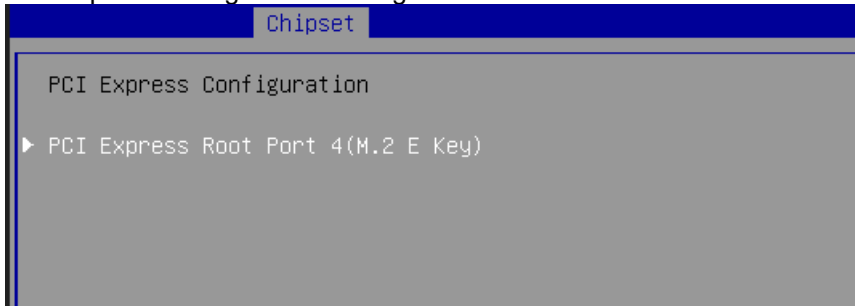

- **PCI Express Root Port 4(M.2 E Key)**

Control the PCI-Express root port (M.2 E Key).

- M.2 B Key: R680E SKU only.

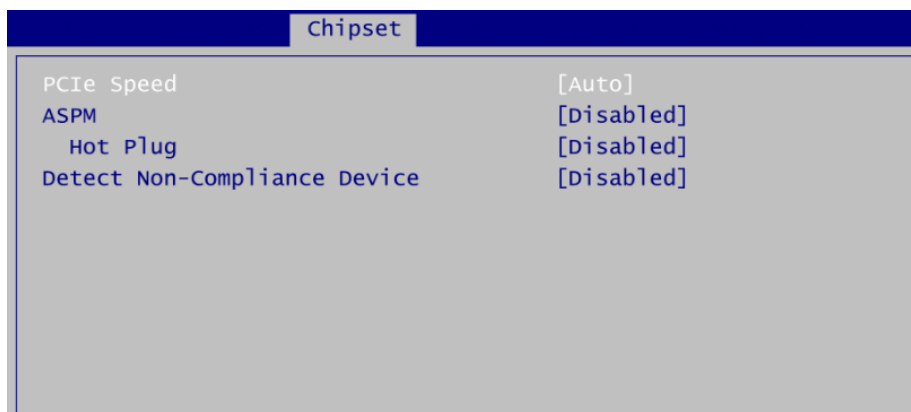

PCIe Speed

Allow user to configure PCI-Express speed.

ASPM

Sets the ASPM (Active State Power Management Settings) level:

- Force L0: Force all links to L0 state.
- Auto: BIOS auto configures.
- Disabled: Disables ASPM.

Hot Plug

Enable or disable PCI-Express Hot Plug.

Detect Non-Compliance Device

Enable or disable the detection of a non-compliance PCI-Express device in PEG.

HD Audio Configuration

HD Audio subsystem configuration settings.

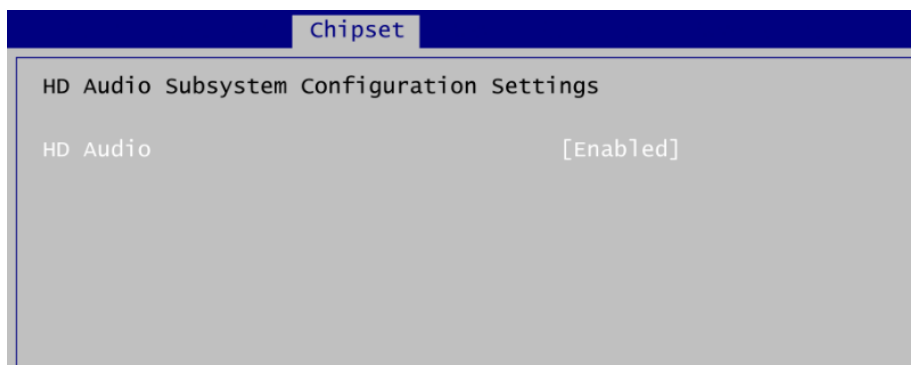

HD Audio

Control detection of the HD Audio device.

- Disabled: HDA will be unconditionally disabled.
- Enabled: HDA will be unconditionally enabled.

4.6 Security Menu

The Security menu allows users to change the security settings for the system.



Administrator Password

Set administrator password. If only the Administrator password is set, it restricts access to BIOS Setup and is required only when entering Setup.

User Password

Set password. If only the User password is set, it acts as a power-on password and is required to boot or enter Setup. In Setup, the User has Administrator rights.

Secure Boot

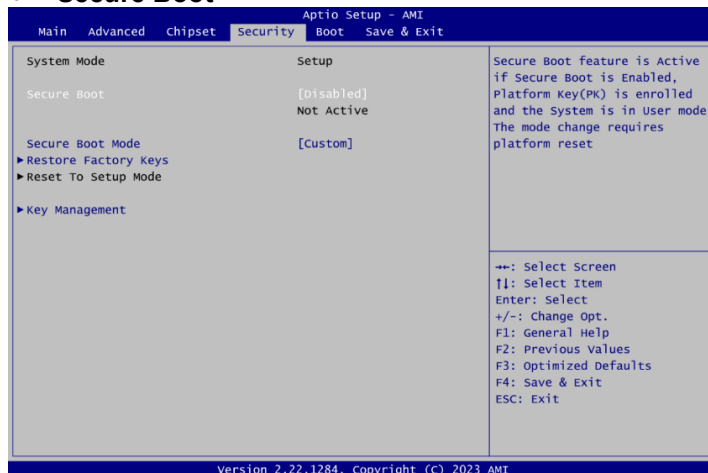

Secure Boot

Secure Boot becomes active when it is enabled, the Platform Key (PK) is enrolled, and the system is in User Mode. A platform reset is required when changing modes. This feature ensures the system only boots from trusted software by verifying digital signatures of boot loaders, firmware, and operating systems. Users may enable or disable Secure Boot, and select between Standard or Custom mode.

Secure Boot Mode

Secure Boot mode options: Standard or Custom. In Custom mode, the policy of Secure Boot variables can be configured by a physically present user without full authentication.

Restore Factory Keys

Force the system into User Mode. Install factory default Secure Boot key databases.

Key Management

Enables expert users to modify Secure Boot Policy variables without full authentication.

4.7 Boot Menu

The Boot menu allows users to change boot options of the system.

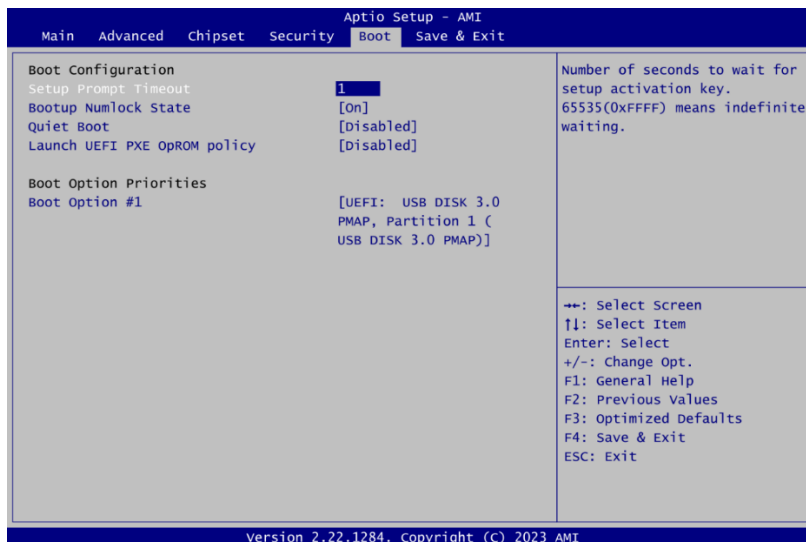

- Setup Prompt Timeout**
 Number of seconds to wait for setup activation key. 65535(0xFFFF) means indefinite waiting.

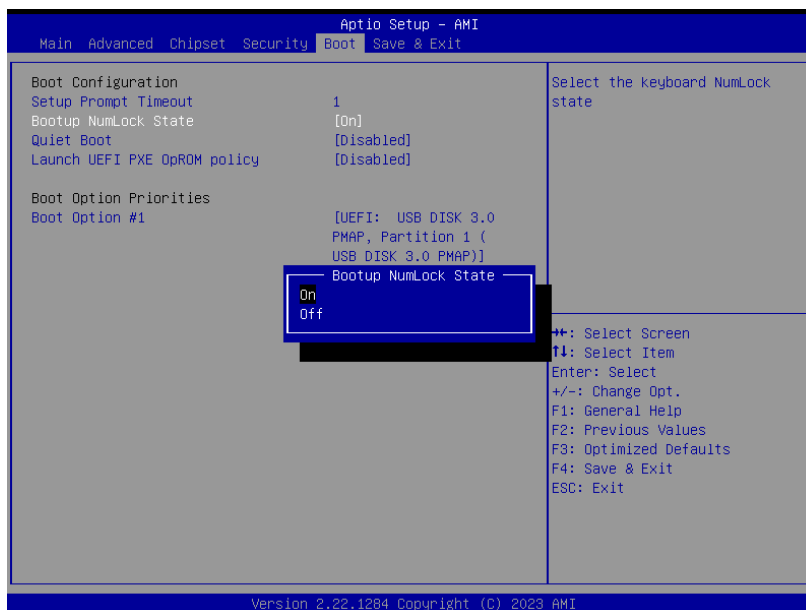

- Bootup NumLock State**
 Use this item to select the power-on state for the keyboard NumLock.

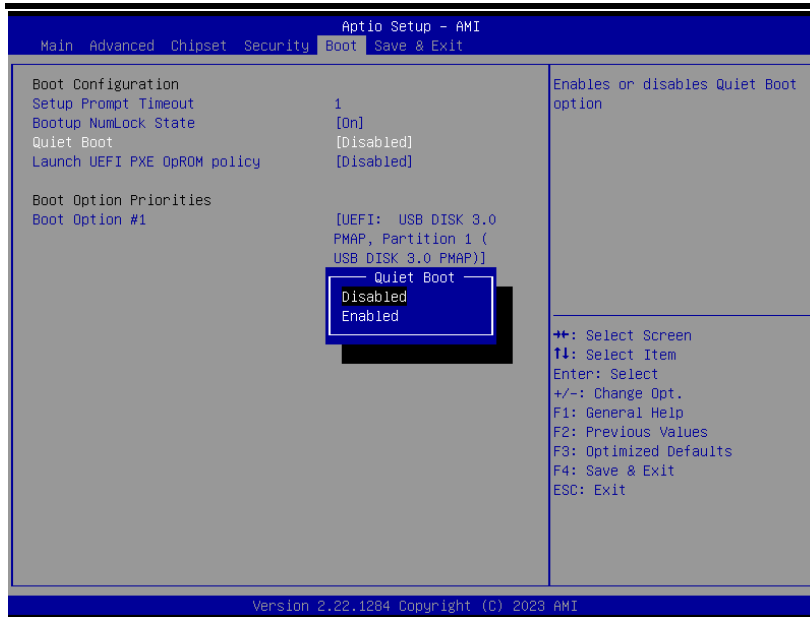

- **Quiet Boot**
Select to display either POST output messages or a splash screen during boot-up.

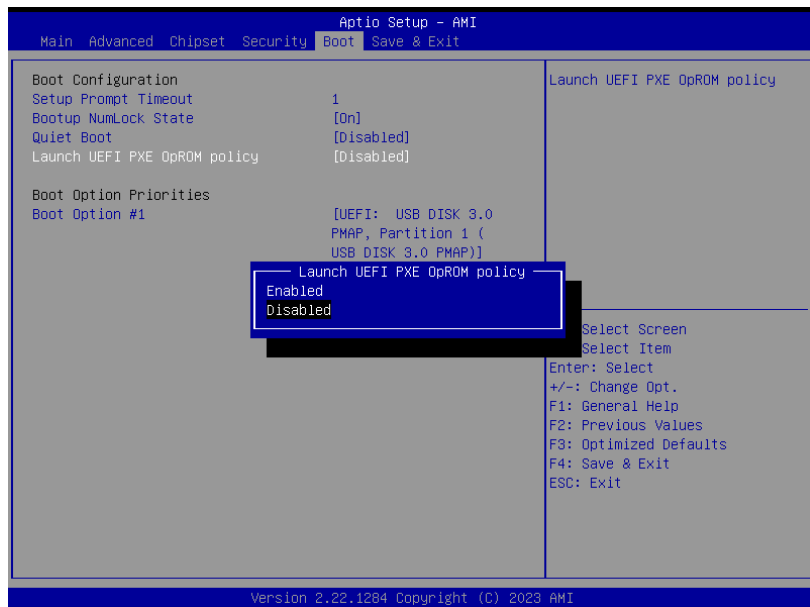

- **Launch UEFI PXE OpROM policy**
Control the execution of UEFI PXE OpROM. When enabled, you may select LAN1 or LAN2 as PXE LAN port.
- **Boot Option Priorities**
These are settings for boot priority. Specify the boot device priority sequence from the available devices.

4.8 Save & Exit Menu

The Save & Exit menu allows users to load your system configuration with optimal or fail-safe default values.

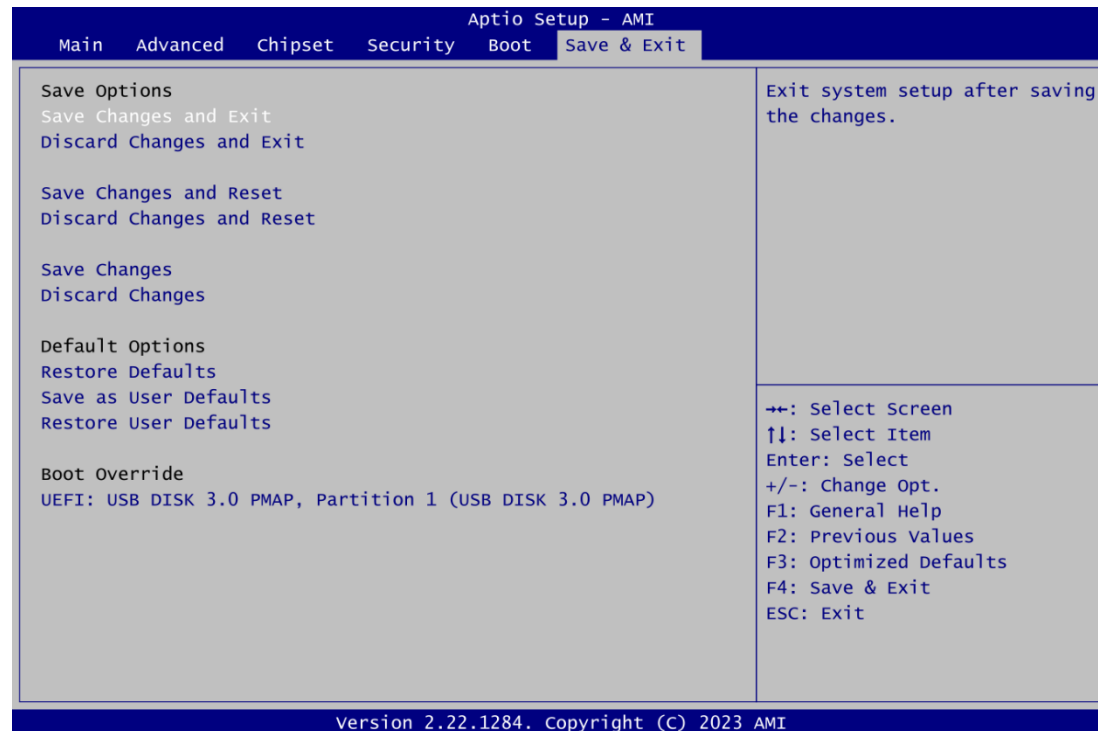

- Save Changes and Exit**
 When you have completed the system configuration changes, select this option to leave Setup and return to Main Menu. Select Save Changes and Exit from the Save & Exit menu and press <Enter>. Select Yes to save changes and exit.
- Discard Changes and Exit**
 Select this option to quit Setup without making any permanent changes to the system configuration and return to Main Menu. Select Discard Changes and Exit from the Save & Exit menu and press <Enter>. Select Yes to discard changes and exit.
- Save Changes and Reset**
 When you have completed the system configuration changes, select this option to leave Setup and reboot the computer so the new system configuration parameters can take effect. Select Save Changes and Reset from the Save & Exit menu and press <Enter>. Select Yes to save changes and reset.
- Discard Changes and Reset**
 Select this option to quit Setup without making any permanent changes to the system configuration and reboot the computer. Select Discard Changes and Reset from the Save & Exit menu and press <Enter>. Select Yes to discard changes and reset.
- Save Changes**
 When you have completed the system configuration changes, select this option to save changes. Select Save Changes from the Save & Exit menu and press <Enter>. Select Yes to save changes.

- **Discard Changes**
Select this option to quit Setup without making any permanent changes to the system configuration. Select Discard Changes from the Save & Exit menu and press <Enter>. Select Yes to discard changes.
- **Restore Defaults**
It automatically sets all Setup options to a complete set of default settings when you select this option. Select Restore Defaults from the Save & Exit menu and press <Enter>.
- **Save as User Defaults**
Select this option to save system configuration changes done so far as User Defaults. Select Save as User Defaults from the Save & Exit menu and press <Enter>.
- **Restore User Defaults**
It automatically sets all Setup options to a complete set of User Defaults when you select this option. Select Restore User Defaults from the Save & Exit menu and press <Enter>.
- **Boot Override**
Select a drive to immediately boot that device regardless of the current boot order.

This page is intentionally left blank.

Appendix A

Watchdog Timer

A.1 About Watchdog Timer

Software stability is major issue in most application. Some embedded systems are not watched by human for 24 hours. It is usually too slow to wait for someone to reboot when computer hangs. The systems need to be able to reset automatically when things go wrong. The watchdog timer gives us solution.

The watchdog timer is a counter that triggers a system reset when it counts down to zero from a preset value. The software starts counter with an initial value and must reset it periodically. If the counter ever reaches zero which means the software has crashed, the system will reboot.

A.2 Sample Code

```

////////////////////////////////////
#include <stdio.h>
#include <stdlib.h>

#include <sys/io.h>

#define SIO_INDEX 0x2E
#define SIO_DATA 0x2F

#define SIO_ENTRY_KEY 0x87
#define SIO_EXIT_KEY 0xAA

#define SIO_LD_WDT 0x07

#define SIO_REG_LDN 0x07
#define SIO_REG_ACTIVATE 0x30
#define SIO_REG_IOBASE_HIGH 0x60
#define SIO_REG_IOBASE_LOW 0x61

#define WDT_IOBASE_HIGH 0x0A
#define WDT_IOBASE_LOW 0x10
#define WDT_IOBASE 0x0A10
#define WDT_CONFIG 0x05
#define WDT_TIME 0x06

int main()
{
    unsigned char Count = 10; // 10 Seconds
    unsigned char DataBuffer; // Operate Io Data

    //Get Io Port Read/Write Permission
    iopl(3);

    //Enter SIO Config

```

```
outb_p ( SIO_ENTRY_KEY, SIO_INDEX);
outb_p ( SIO_ENTRY_KEY, SIO_INDEX);

// Set WDT IOBASE
// Select Logical Device = 07 (WDT)
outb_p ( SIO_REG_LDN , SIO_INDEX);
outb_p ( SIO_LD_WDT , SIO_DATA);

// set IOBase
outb_p ( SIO_REG_IOBASE_HIGH , SIO_INDEX);
outb_p ( WDT_IOBASE_HIGH , SIO_DATA);

outb_p ( SIO_REG_IOBASE_LOW , SIO_INDEX);
outb_p ( WDT_IOBASE_LOW , SIO_DATA);

// Activate Wdt IO Decode
outb_p ( SIO_REG_ACTIVATE , SIO_INDEX);
outb_p ( 1 , SIO_DATA);

//Exit SIO Config
outb_p ( SIO_EXIT_KEY, SIO_INDEX);

// Clear And Set Wdt Status
/*
Wdt Config Reg Bit Definition
7 : Reserved
6 : WDT time out Status (Write 1 Clear)
5 : Watch dog counting Enable
4 : Set Output mode (0 Level,1 Edge)
3 : Time Unit (0 : 1sec , 1: 60Sec)
2 : Output Polarity (0 : low active , 1 : High active)
1-0 : (output pulse width of Wdtrst# ,
      00 1ms , 01 25ms ,
      10 125ms ,11 :5sec)
*/
outb_p ( 0x40 , WDT_IOBASE + WDT_CONFIG);
//Set WatchDog Count Time
outb_p ( Count , WDT_IOBASE + WDT_TIME);

//Start WatchDog Count
outb_p ( 0x20 , WDT_IOBASE + WDT_CONFIG);

//Print Remain Time
while(1)
{
    DataBuffer = inb_p ( WDT_IOBASE + WDT_TIME );
    printf(" reset in %d sec\n",DataBuffer);
}
return 0;
}
////////////////////////////////////////////////////////////////////////////////////////////////////////////////////////////////
```

Appendix B

Digital I/O

B.1 Digital I/O Programming

1. IOBASE: 0xEFA0
2. Registers:
Command byte

Command	Protocol	Function
0	Read byte	Input port register
1	Read/write byte	Output port register
2	Read/write byte	Polarity inversion register
3	Read/write byte	Configuration register

The command byte is the first byte to follow the address byte during a write transmission. It is used as a pointer to determine which of the following registers will be written or read.

Register 0: Input port register.

This register is a read-only port. It reflects the incoming logic levels of the pins, regardless of whether the pin is defined as an input or an output by Register 3. Writes to this register have no effect. The default 'X' is determined by the externally applied logic level, normally '1' when no external signal is externally applied because of the internal pull-up resistors.

Bit	Symbol	Access	Value	Description
7	I7	Read only	X	Determined by externally applied logic level.
6	I6	Read only	X	
5	I5	Read only	X	
4	I4	Read only	X	
3	I3	Read only	X	
2	I2	Read only	X	
1	I1	Read only	X	
0	I0	Read only	X	

Register 1: Output port register.

This register reflects the outgoing logic levels of the pins defined as outputs by Register 3. Bit values in this register have no effect on pins defined as inputs. Reads from this register return the value that is in the flip-flop controlling the output selection, not the actual pin value.

Bit	Symbol	Access	Value	Description
7	O7	R	1*	Reflects outgoing logic levels of pins defined as outputs by Register 3.
6	O6	R	1*	
5	O5	R	1*	
4	O4	R	1*	
3	O3	R	1*	
2	O2	R	1*	
1	O1	R	1*	
0	O0	R	1*	

* : Default value

Register 3: Configuration register.

This register configures the directions of the I/O pins. If a bit in this register is set, the corresponding port pin is enabled as an input with a high-impedance output driver. If a bit in this register is cleared, the corresponding port pin is enabled as an output. At reset, the I/Os are configured as inputs with a weak pull-up to VDD.

Bit	Symbol	Access	Value	Description
7	C7	R/W	1*	Configure the directions of the I/O pins. 0 = Corresponding port pin enabled as an output. 1 = Corresponding port pin configured as input (default value).
6	C6	R/W	1*	
5	C5	R/W	1*	
4	C4	R/W	1*	
3	C3	R/W	1*	
2	C2	R/W	1*	
1	C1	R/W	1*	
0	C0	R/W	1*	

* : Default value

B.2 Sample Code

```

////////////////////////////////////
#include <stdio.h>
#include <stdlib.h>

#include <sys/io.h>

//SMBUS IO base, Host Status Register Address (HSTS)
#define HSTS 0xEFA0
//Host Control Register (HCTL)
#define HCTL 0xEFA2
//Host Command Register (HCMD)
#define HCMD 0xEFA3
//Transmit Slave Address Register (TSA)
#define TSA 0xEFA4
//Data 0 Register (HD0)
#define HD0 0xEFA5
#define DIO_SLAVE_ADDR_WRITE 0x44
#define DIO_SLAVE_ADDR_READ 0x45
#define DIO_INPUT_OFFSET 0x00
#define DIO_OUTPUT_OFFSET 0x01
#define DIO_CONFIG_OFFSET 0x03

// Set DIO to output and print configuration register value
int SetDIO_to_output()
{
    unsigned char config_value;
    //Get Io Port Read/Write Permission
    iopl(3);
    // Clear host status register
    outb_p (0xFF, HSTS);

    //Set DIO device slave address and set command to write(slave
    //addr+0)
    outb_p ( DIO_SLAVE_ADDR_WRITE, TSA);

    //Set DIO offset to configuration register
    outb_p ( DIO_CONFIG_OFFSET, HCTL);

    //Set DIO configuration register bit 0~7 to 0 which means set all

```

```

//DIO ports to output (0 -> output, 1 -> input)
outb_p (0x0, HD0);

//Raise the START bit(bit 6) of HCTL and set SMB_CMD (bit2~4) of
//HCTL to 0x010(Byte Data) to start transfer
outb_p (0x48, HCTL);

//print configuration register value
// Clear host status register
outb_p (0xFF, HSTS);

//Set DIO device slave address and set command to read(slave //addr+1)
outb_p ( DIO_SLAVE_ADDR_READ, TSA);

//Set DIO offset to configuration register
outb_p ( DIO_CONFIG_OFFSET, HCTL);

//Raise the START bit(bit 6) of HCTL and set SMB_CMD (bit2~4) of
//HCTL to 0x010(Byte Data) to start transfer
outb_p (0x48, HCTL);
//Read from HS0 to print configuration register value
config_value = inb_p (HD0);
printf(" configuration value = %d\n",config_value);

return 0;
}

// Set DIO output to low/high
int SetDIOoutput_low_high()
{
    //Get Io Port Read/Write Permission
    iopl(3);
    // Clear host status register
    outb_p (0xFF, HSTS);

    //Set DIO device slave address and set command to write(slave
//addr+0)
    outb_p ( DIO_SLAVE_ADDR_WRITE, TSA);

    //Set DIO offset to output register
    outb_p ( DIO_OUTPUT_OFFSET, HCTL);

    //Set DIO 0~3 output low, 4~7 output high by configure DIO output
//port register bit 0~7, 0x0F means bit 0~3 =1, 4~7 =0, 0-> low,
// 1->high
    outb_p (0x0F, HD0);
    //Raise the START bit(bit 6) of HCTL and set SMB_CMD (bit2~4) of
//HCTL to 0x010(Byte Data) to start transfer
    outb_p (0x48, HCTL);

    return 0;
}

// Set DIO to input and print status (should be 0xFF, all ports read
high)
int SetDIO_to_input()
{
    unsigned char input_value;
    //Get Io Port Read/Write Permission
    iopl(3);
    // Clear host status register

```

```
    outb_p (0xFF, HSTS);

    //Set DIO device slave address and set command to write(slave
//addr+0)
    outb_p ( DIO_SLAVE_ADDR_WRITE, TSA);

    //Set DIO offset to configuration register
    outb_p ( DIO_CONFIG_OFFSET, HCTL);

    //Set DIO configuration register bit 0~7 to 1 which means set all
//DIO ports to input (0 -> output, 1 -> input)
    outb_p (0xFF, HD0);

    //Raise the START bit(bit 6) of HCTL and set SMB_CMD (bit2~4) of
//HCTL to 0x010(Byte Data) to start transfer
    outb_p (0x48, HCTL);

    //print configuration register value
    // Clear host status register
    outb_p (0xFF, HSTS);

    //Set DIO device slave address and set command to read(slave //addr+1)
    outb_p ( DIO_SLAVE_ADDR_READ, TSA);

    //Set DIO offset to configuration register
    outb_p ( DIO_INPUT_OFFSET, HCTL);

    //Raise the START bit(bit 6) of HCTL and set SMB_CMD (bit2~4) of
//HCTL to 0x010(Byte Data) to start transfer
    outb_p (0x48, HCTL);
    //Read from HS0 to print configuration register value
    input_value = inb_p (HD0);
    printf(" input value = %d\n",input_value);

    return 0;
}
```

////////////////////////////////////
This page is intentionally left blank.

Appendix C

iAMT Settings

The Intel® Active Management Technology (Intel® AMT) utilizes built-in platform capabilities and popular third-party management and security applications to allow IT administrators to remotely discover, repair and better protect their networked computing assets, thus significantly improving IT management efficiency. Only Supported Q670E & R680E version

In order to use Intel® AMT you must enter the ME BIOS, change the ME BIOS password, and then select "Intel® iAMT" as the manageability feature.

D.1 Entering MEBx

1. Go to BIOS to enable the iAMT function.

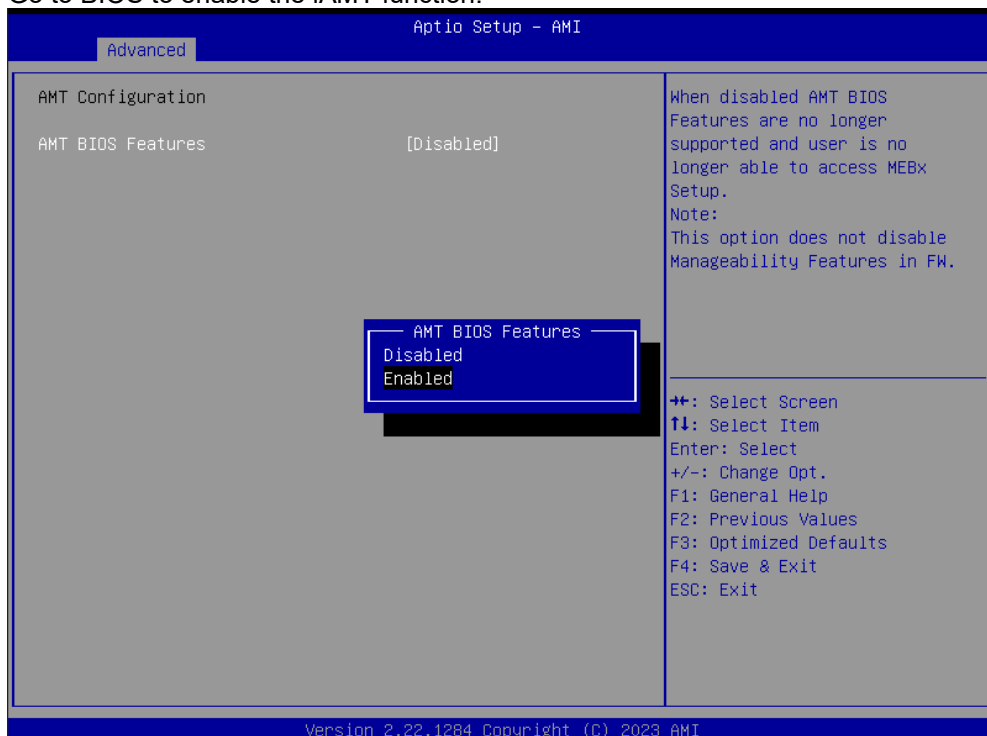

2. After restarting BIOS, exit and enter MEBx Setting.

D.2 Set and Change Password

1. You will be asked to set a password when first logging in. The default password is "admin".
2. You will be asked to change the password before setting ME.
3. You must confirm your new password while revising. The new password must consist of eight characters, including at least:
 - One upper case
 - One lower case
 - One number
 - One special symbol, such as ! , ` \$ or ; , (, ` , excepted)

The default value demonstrates an example of a valid password: **!!11qqQQ**

Underline (_) and space are valid characters for password, but they won't make higher complexity.

D.3 iAMT Settings

Select Intel® iAMT configuration and press <Enter>.

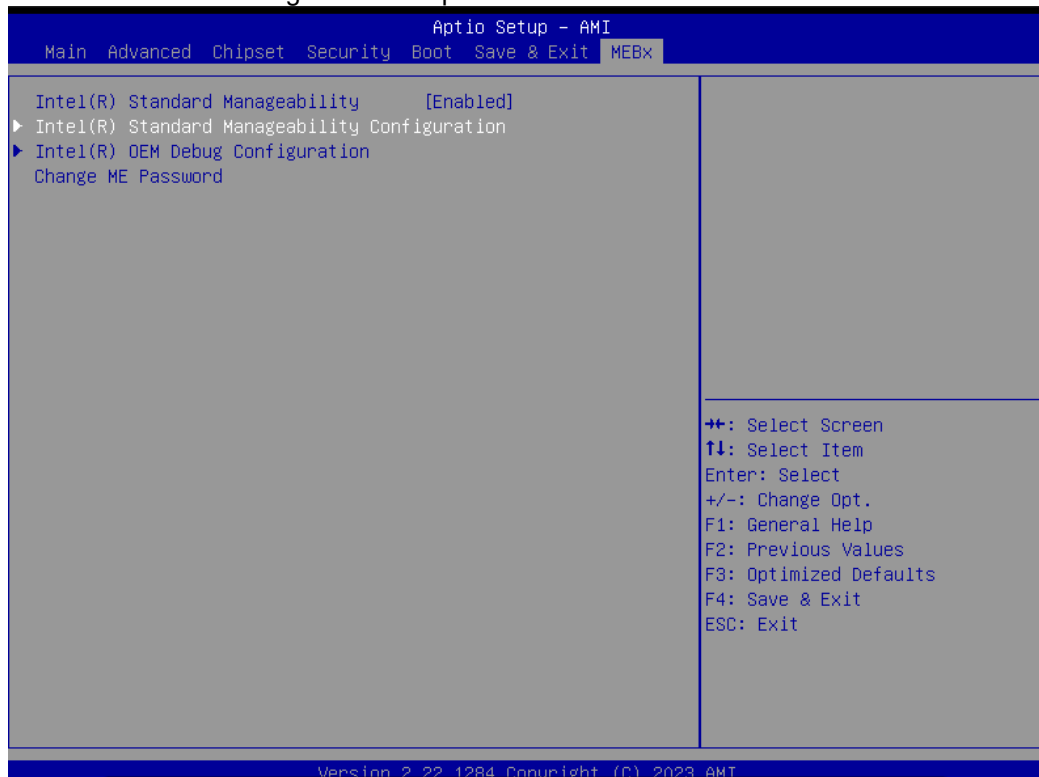

1. Select Network Setup to configure iAMT.

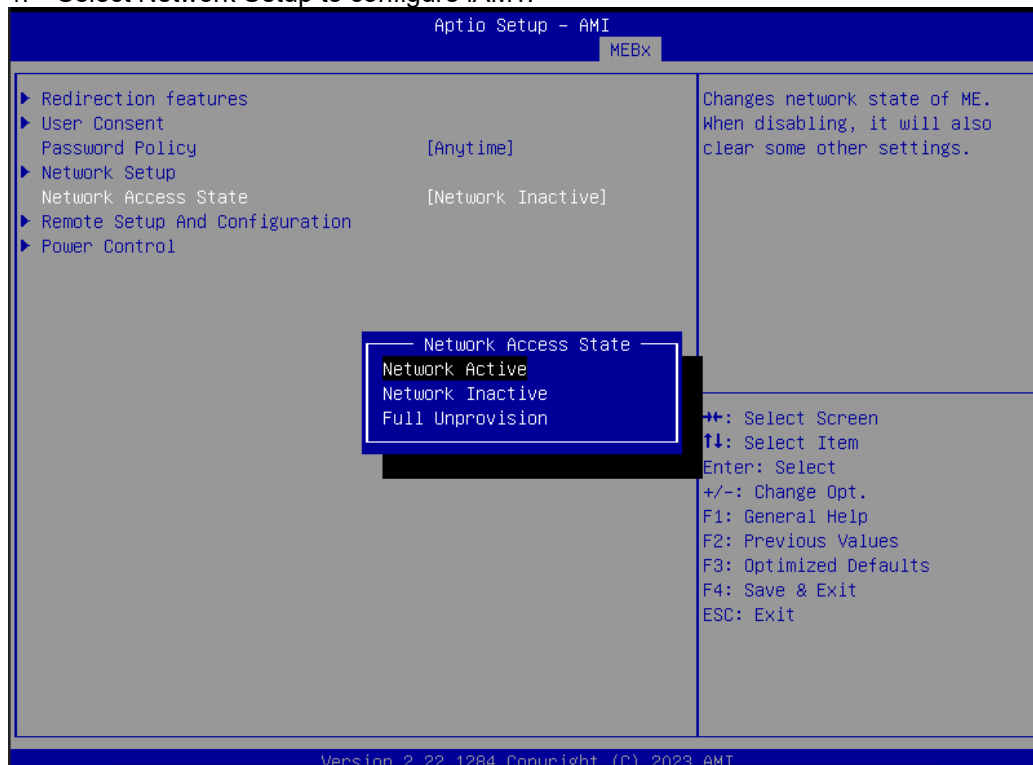

2. Exit from MEBx after completing the iAMT settings.

D.4 iAMT Web Console

1. On a web browser, type `http://(IP ADDRESS):16992`, which connects to iAMT Web.

Example: <http://10.1.40.214:16992>

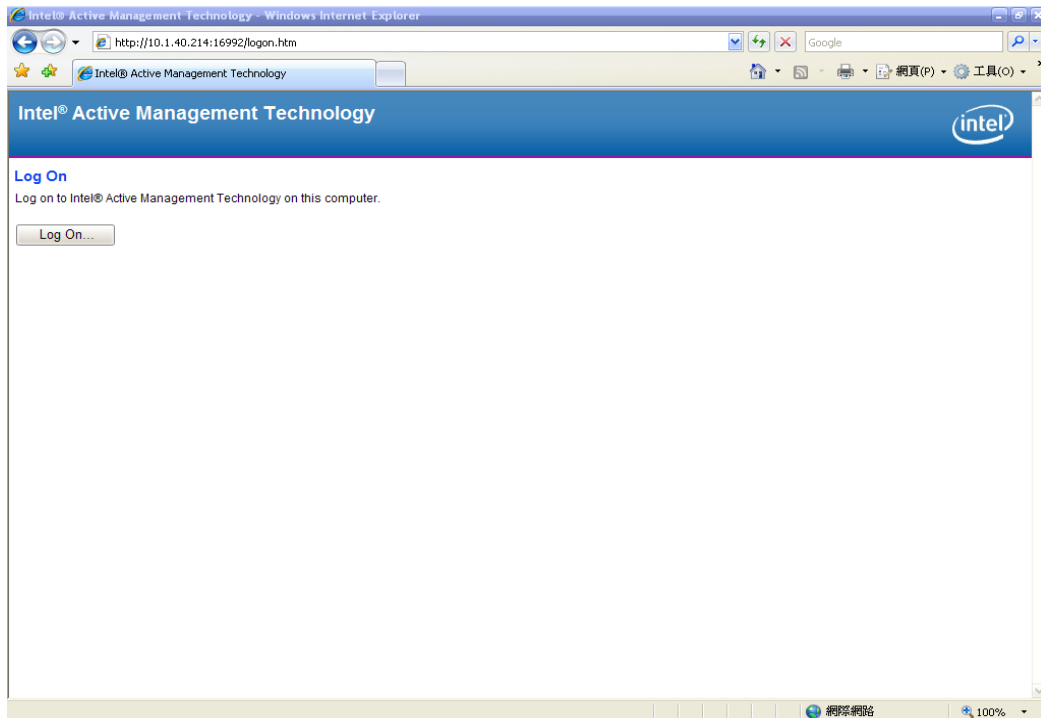

2. To log on, you will be required to type in username and password for access to the Web.

USER: admin (default value)

PASS: (MEBx password)

3. Enter the iAMT Web.

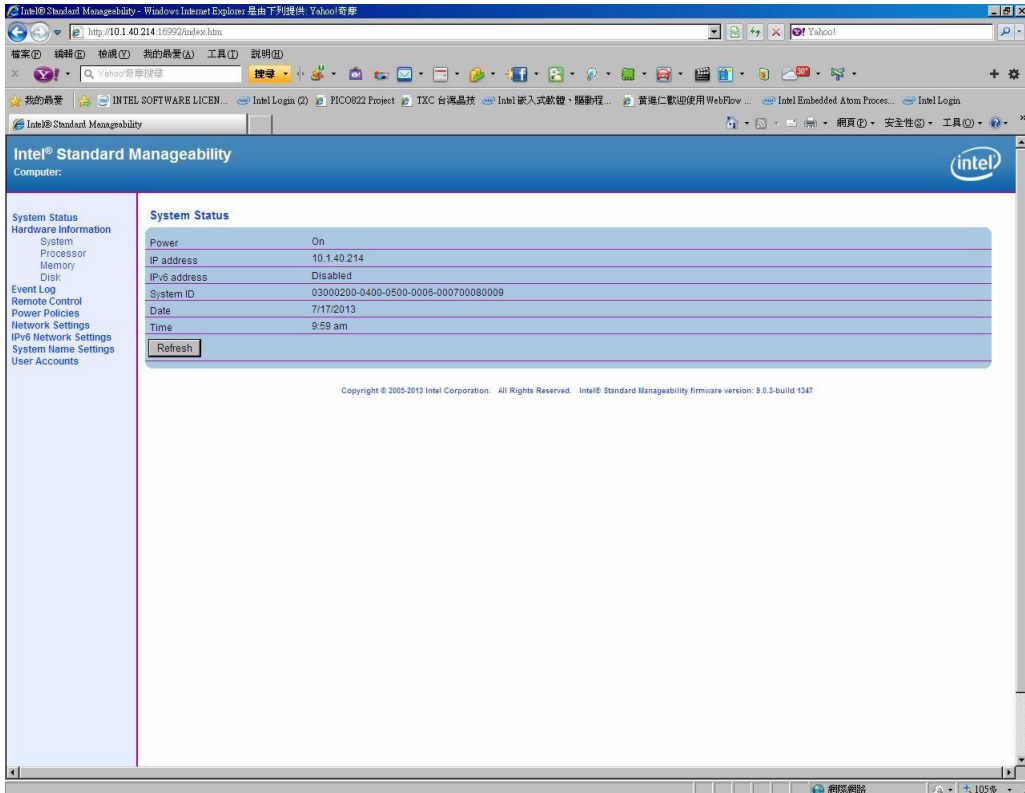

4. Click Remote Control, and select commands on the right side.

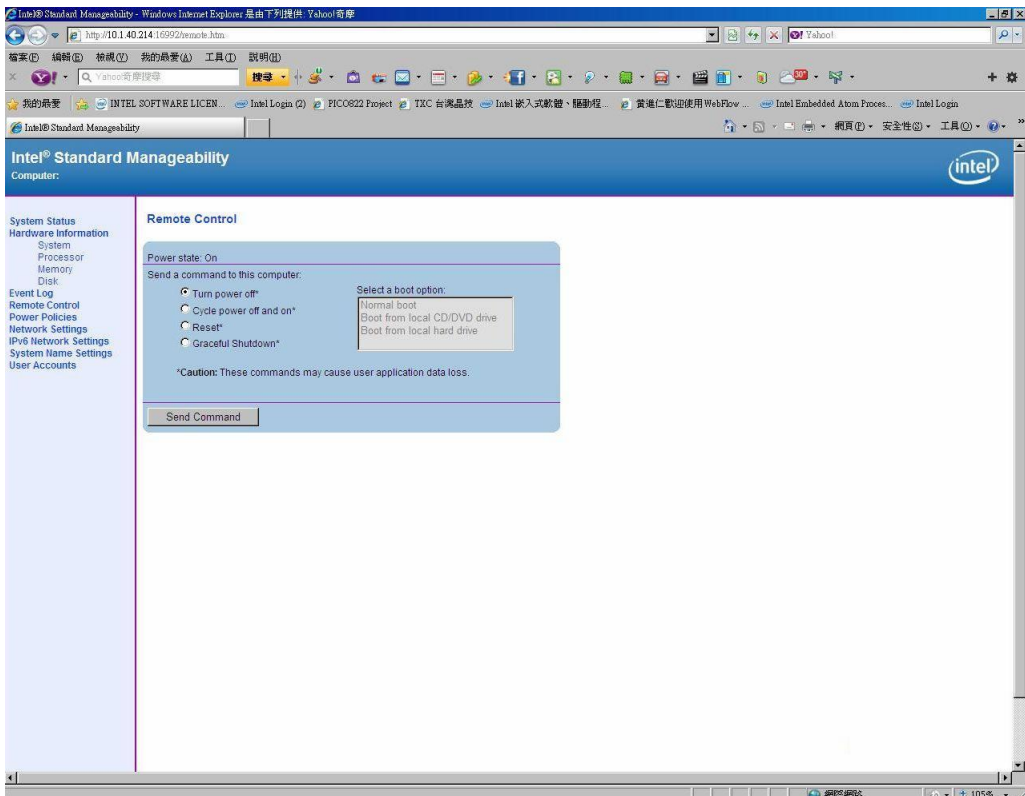

5. When you have finished using the iAMT Web console, close the Web browser.

This page is intentionally left blank.

Appendix D

TPM Settings

1. Setup BitLocker Drive Encryption main storage. Press <Win + R> and type "Control Panel", then select BitLocker Drive Encryption.

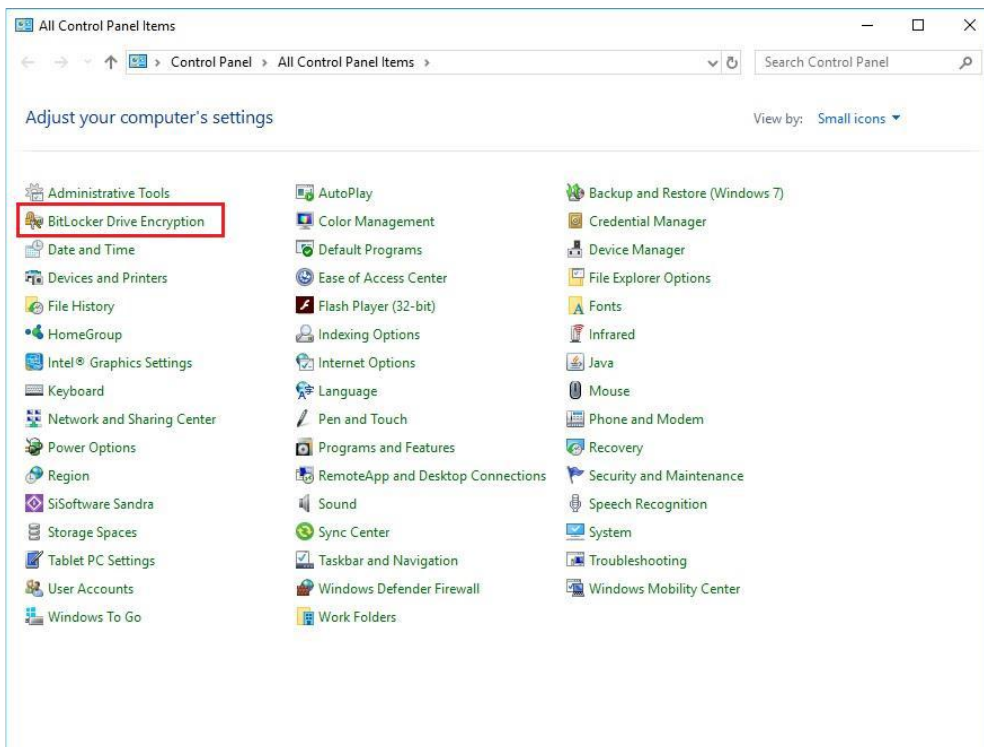
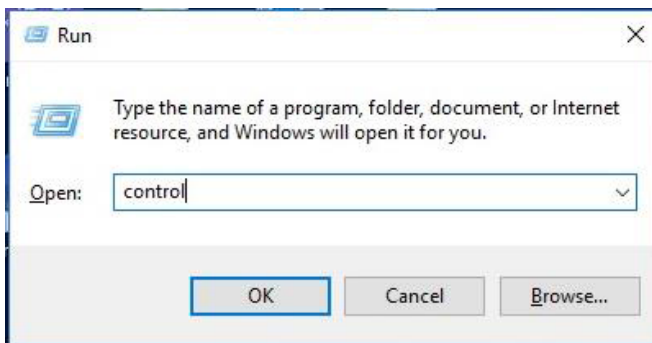

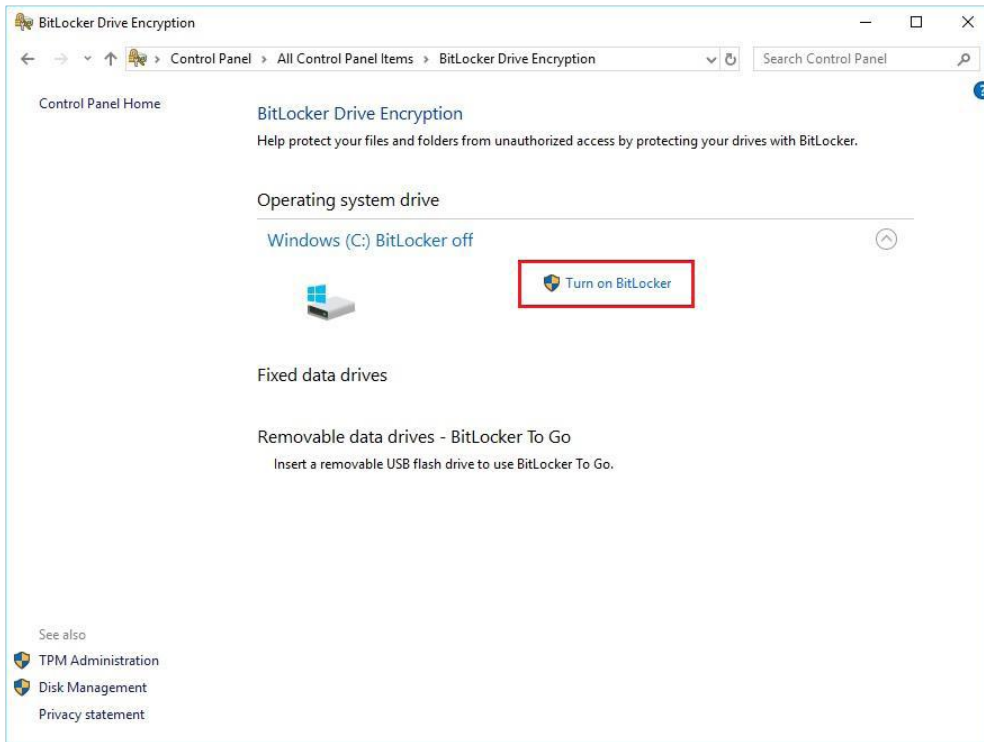

2. Insert an external storage device, for example USB Storage. Back up BitLocker recovery key in a new file and save it to the USB Storage.

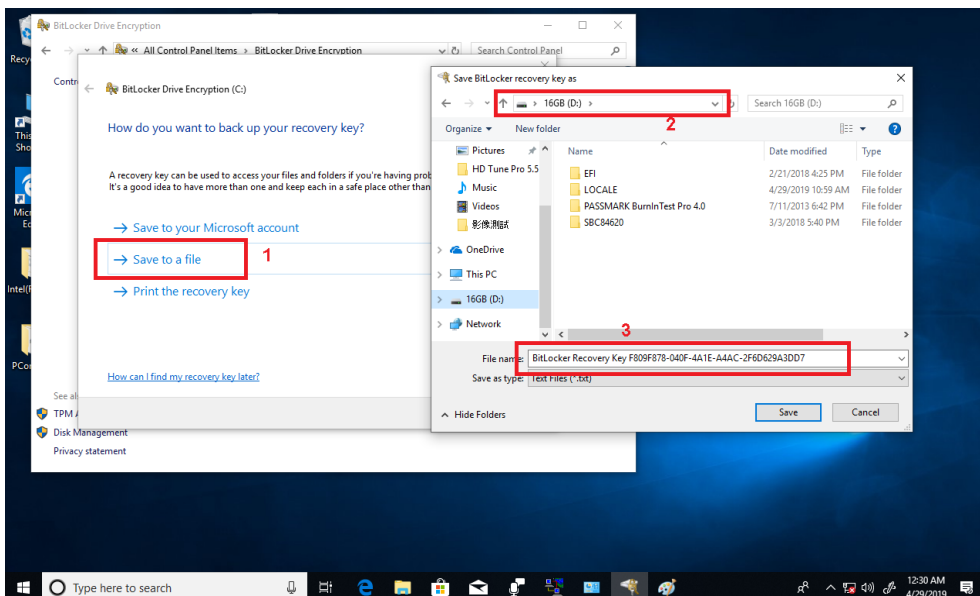

3. Please follow the steps below to encrypt your storage device:

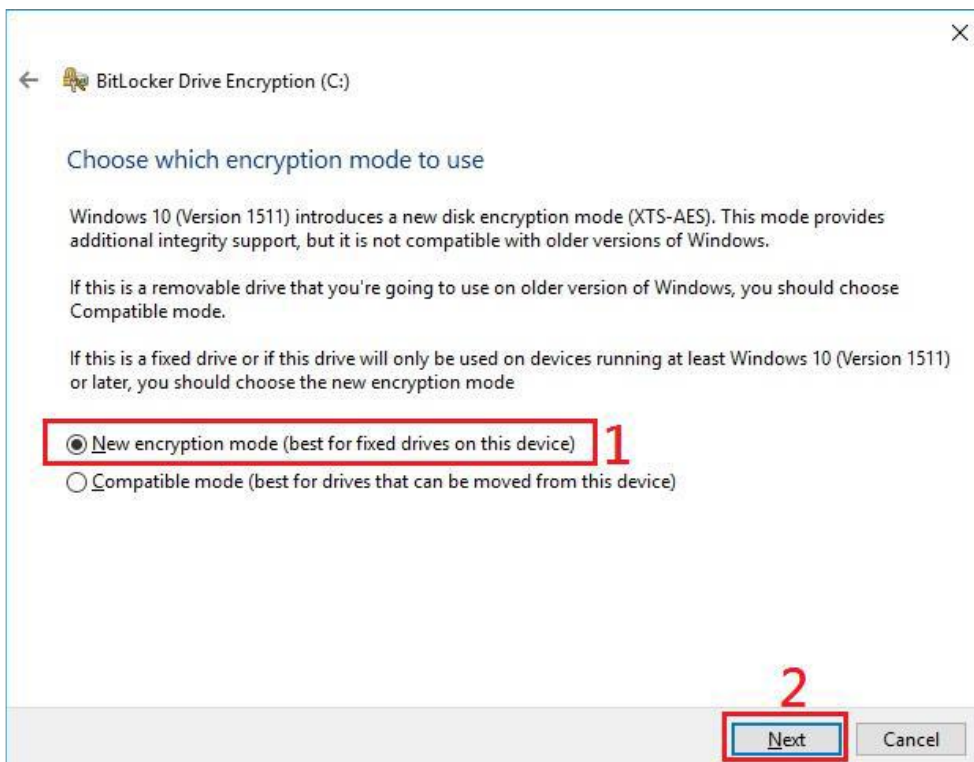
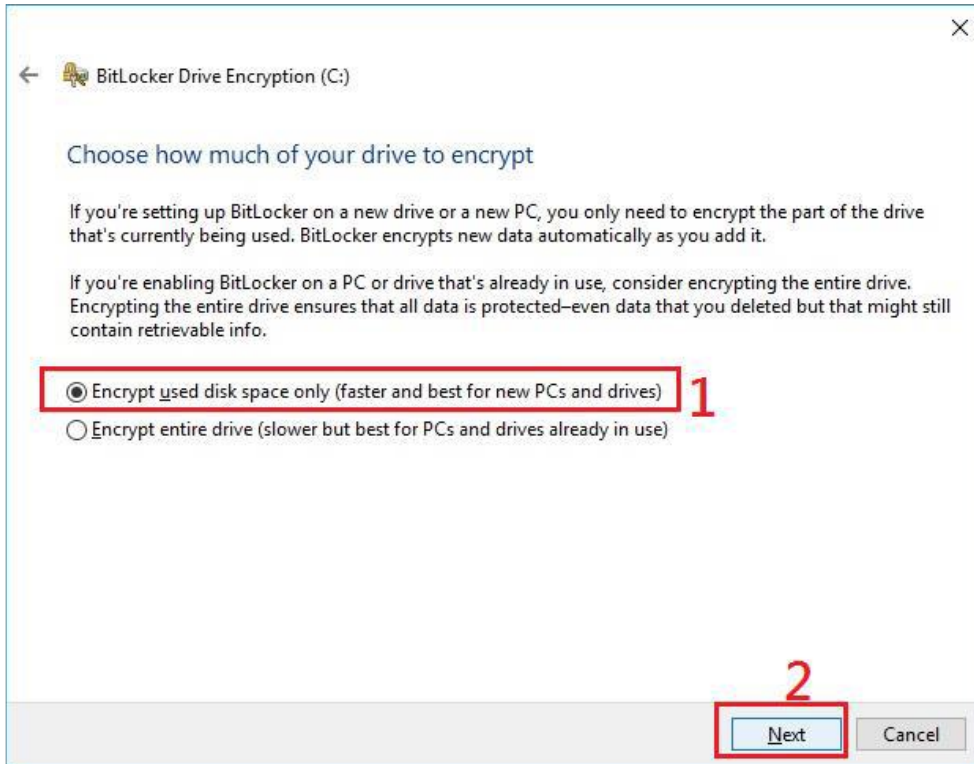

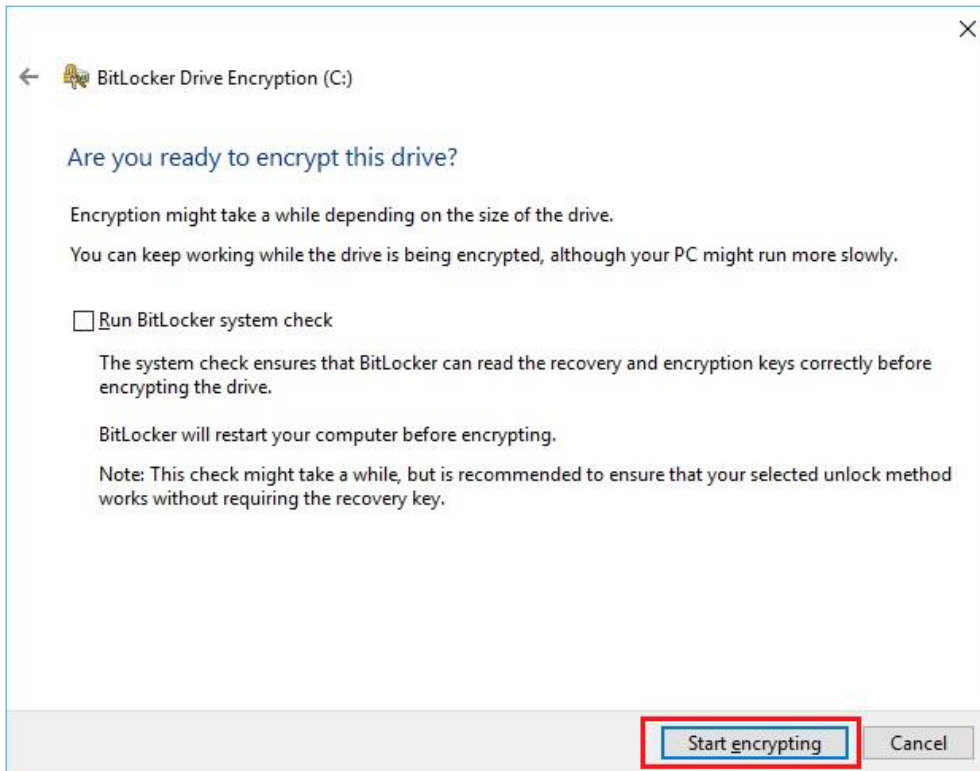

Now, the system prompts that the operating system drive encryption is in progress, and the encryption progress is checked.

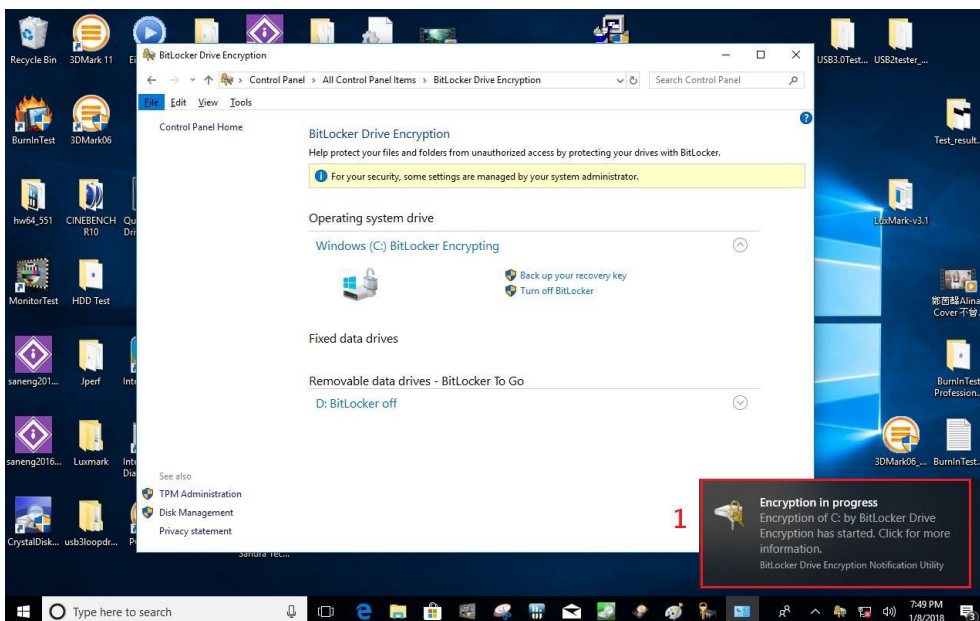

Select and click the icon in the lower right corner to complete the encryption.

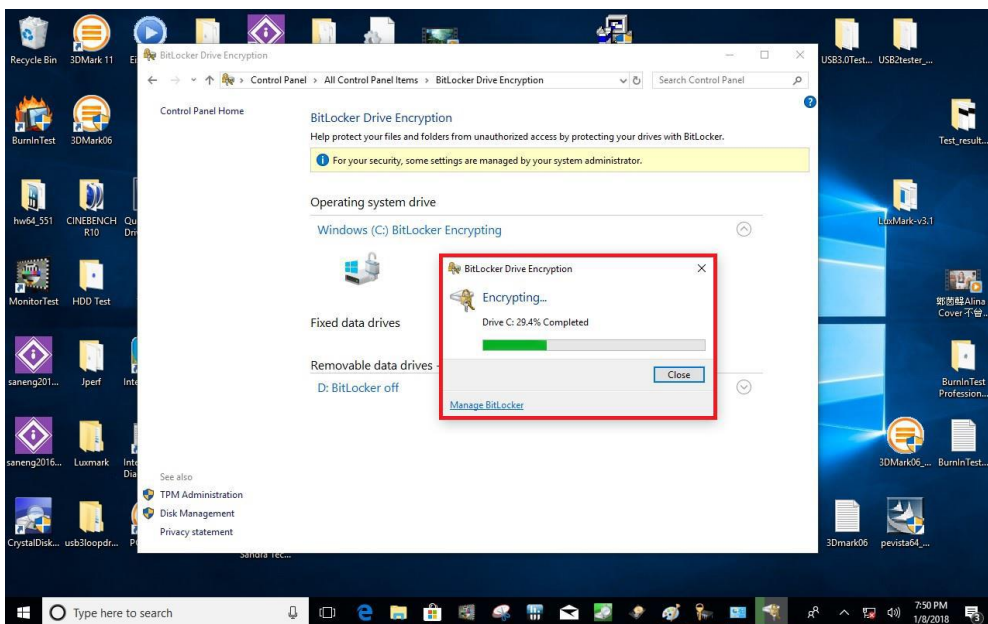
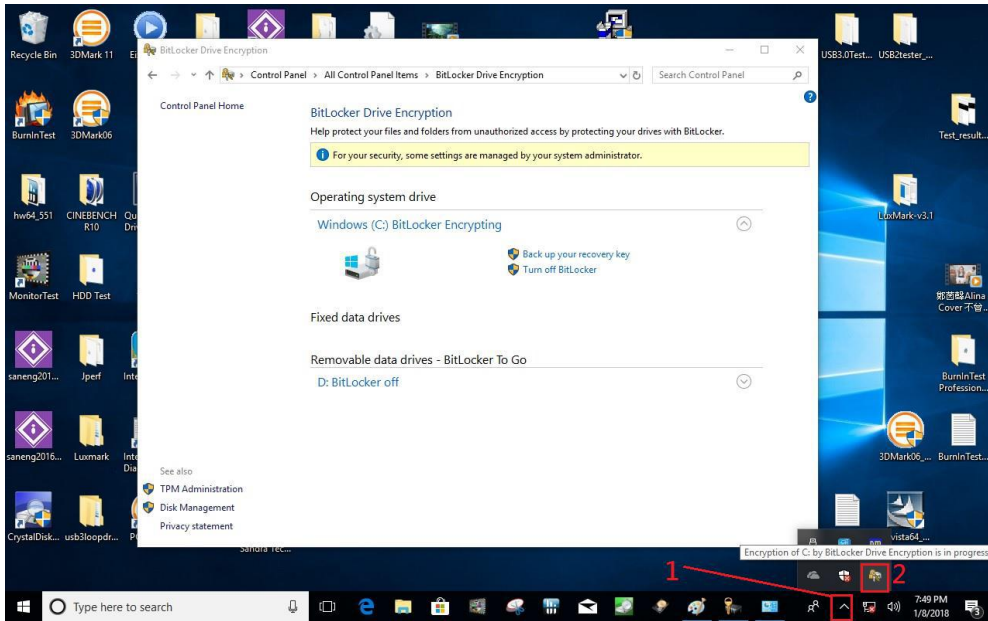

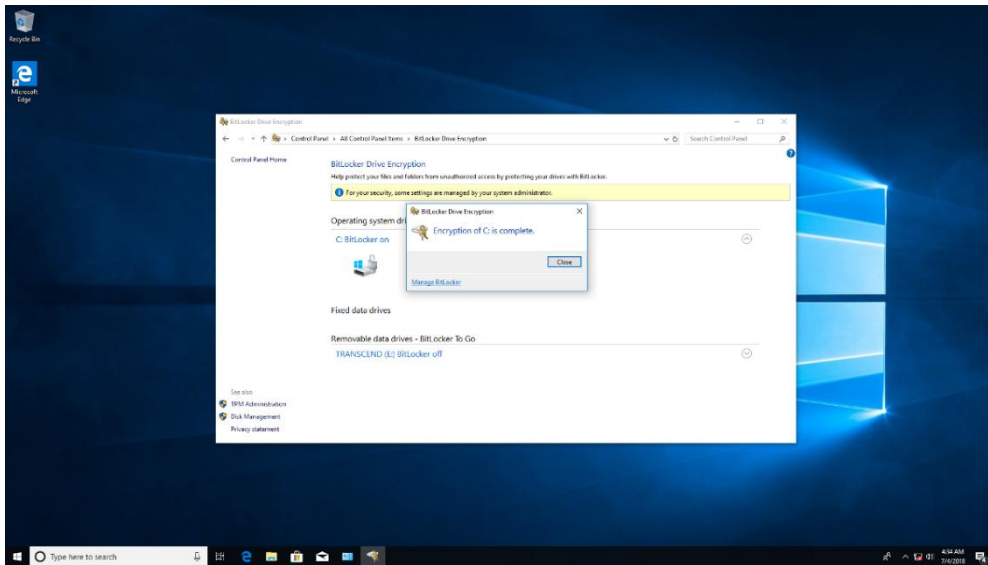

4. Confirm the completion of encryption.

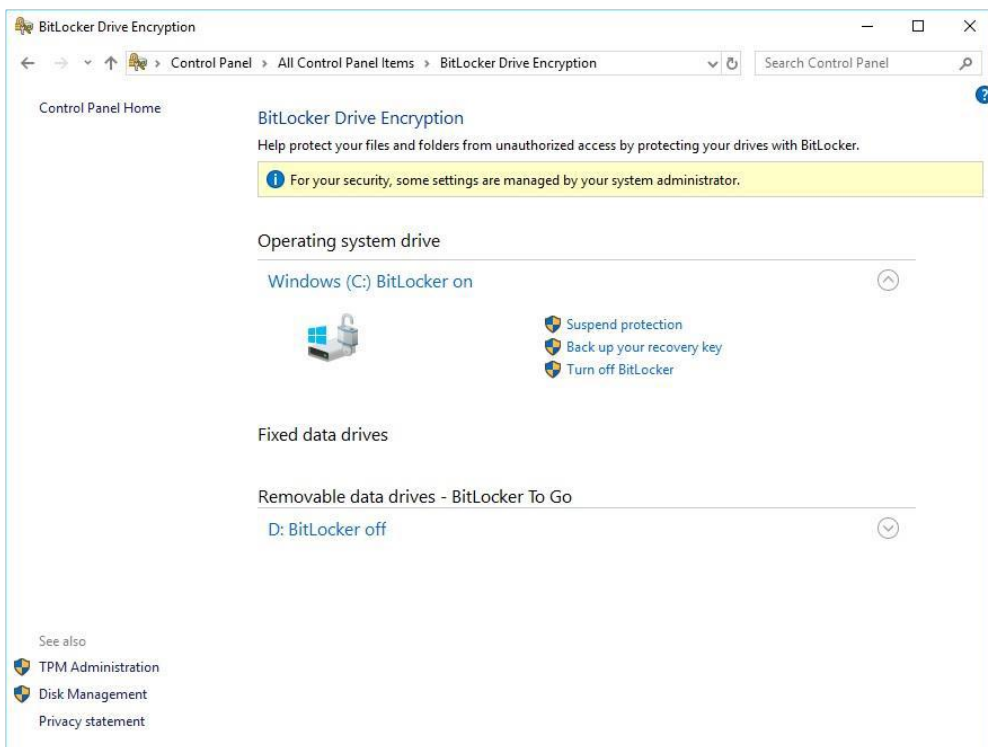

5. Disable TPM function in BIOS Setup Utility.

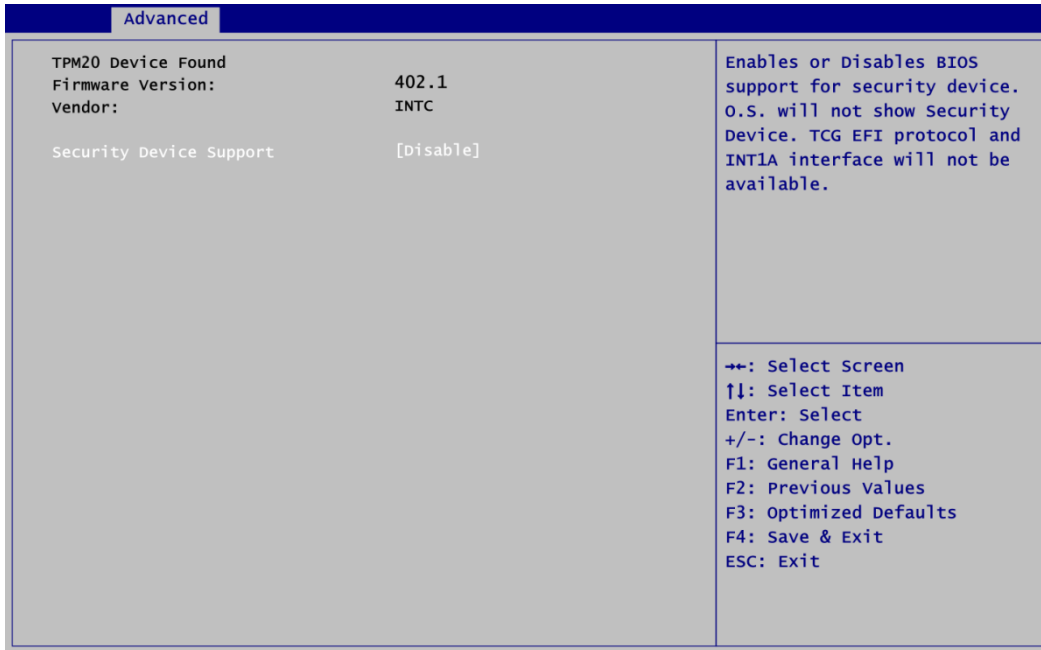

6. When the system is powered on and you see the following screen, it means the TPM module function is working fine. Note that BitLocker cannot be executed if your system does not have TPM function.



System with no TPM function support is as below:



Note

1. **TPM information is not found in Device Manager.**



2. **When trying to turn on BitLocker, the following error message shows up.**

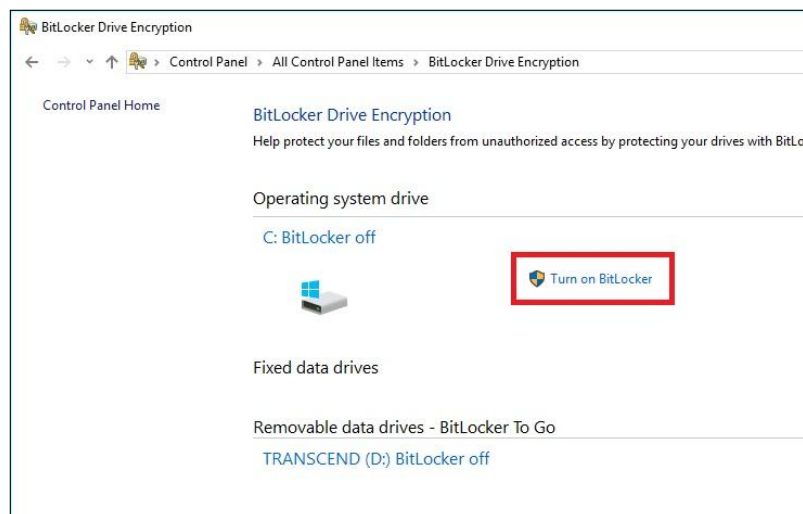

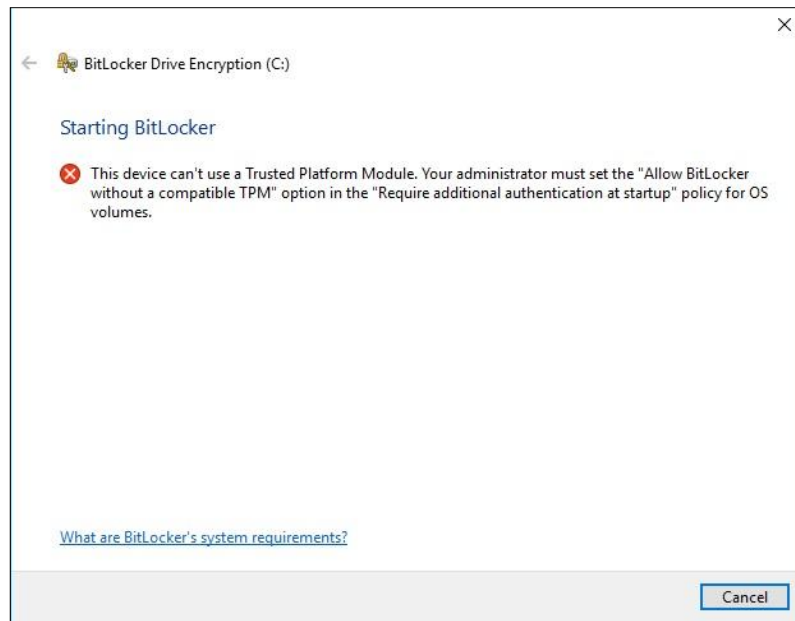

This page is intentionally left blank.

Appendix E

VMD(RAID) Configuration

How to Create Raid? (Only Supported Q670E & R680E version)

Step 1.

In SATA Configuration, Enabled VMD Controller and save&reset.

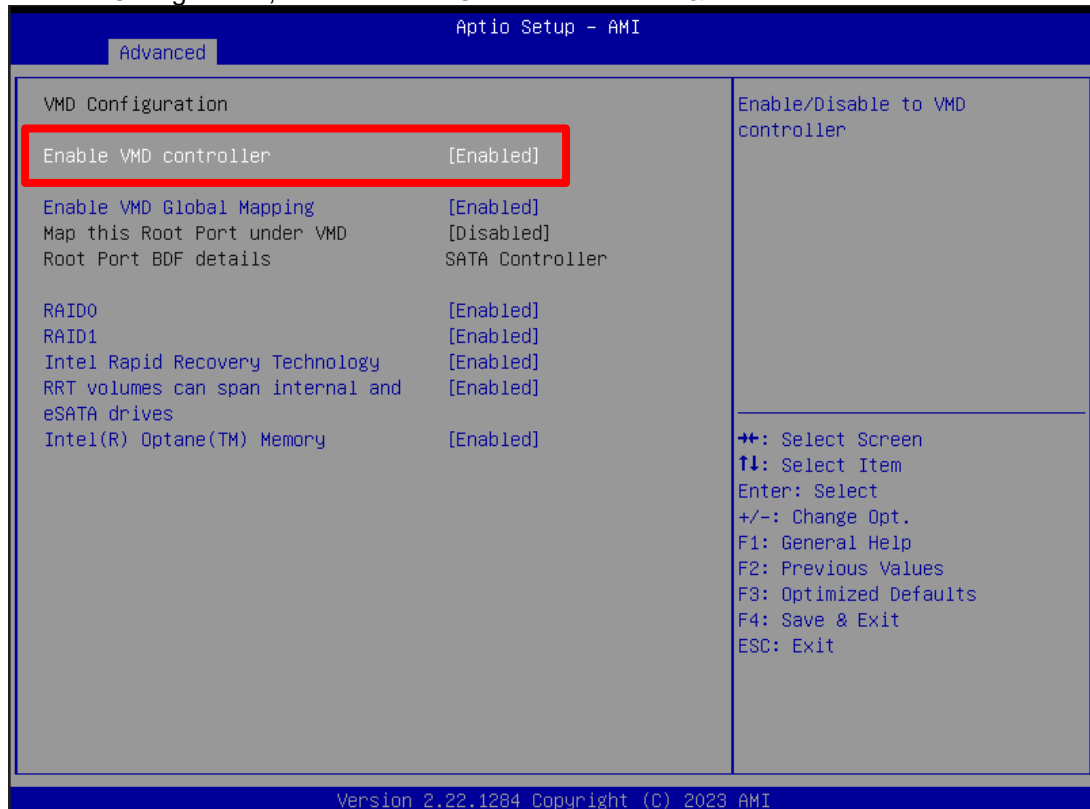

Enable VMD Global Mapping

Enable/Disable to VMD Global Mapping

RAID0

Enable/Disable RAID0 support

RAID1

Enable/Disable RAID1 support

Intel Rapid Recovery Technology

Enable/Disable Intel Rapid Recovery Technology

RRT volumes can span internal and eSATA drives

Enable/Disable RRT volumes can span internal and eSATA drives.

Intel(R) Optane(TM) Memory

Enable/Disable System Acceleration with Intel(R) Optane(TM) Memory feature.

Step2.

After Restart, enter del to Bios Setup Menu. In Advanced Page, choose Intel(R) Rapid Storage Technology.

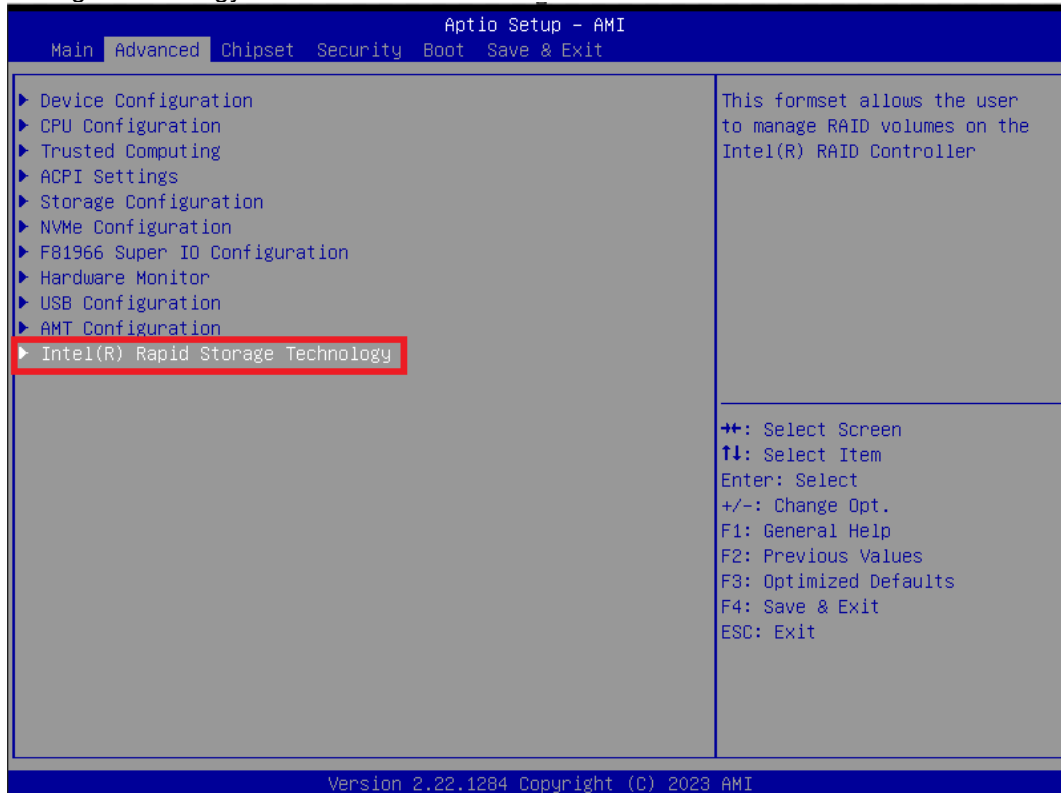

Step3.

In Intel(R) Rapid Storage Technology page. Choose RAID Volume.

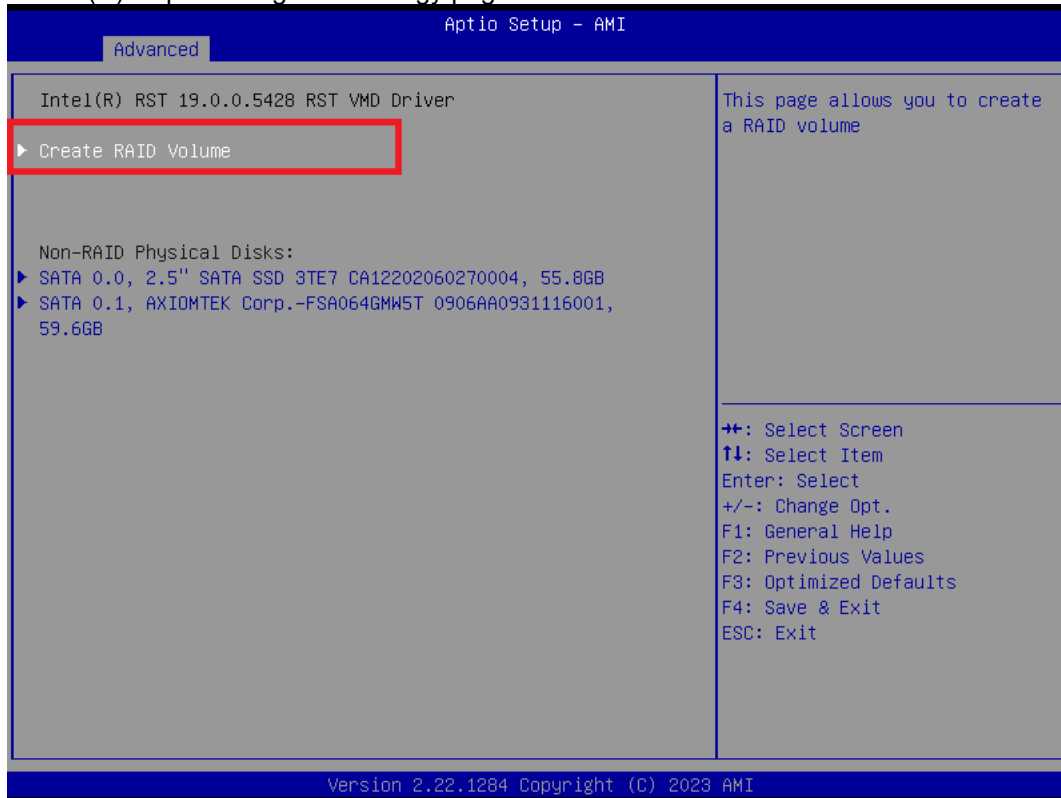

Step 4.

Select RAID Level, correspond to RAID Level in VMD Configuration.

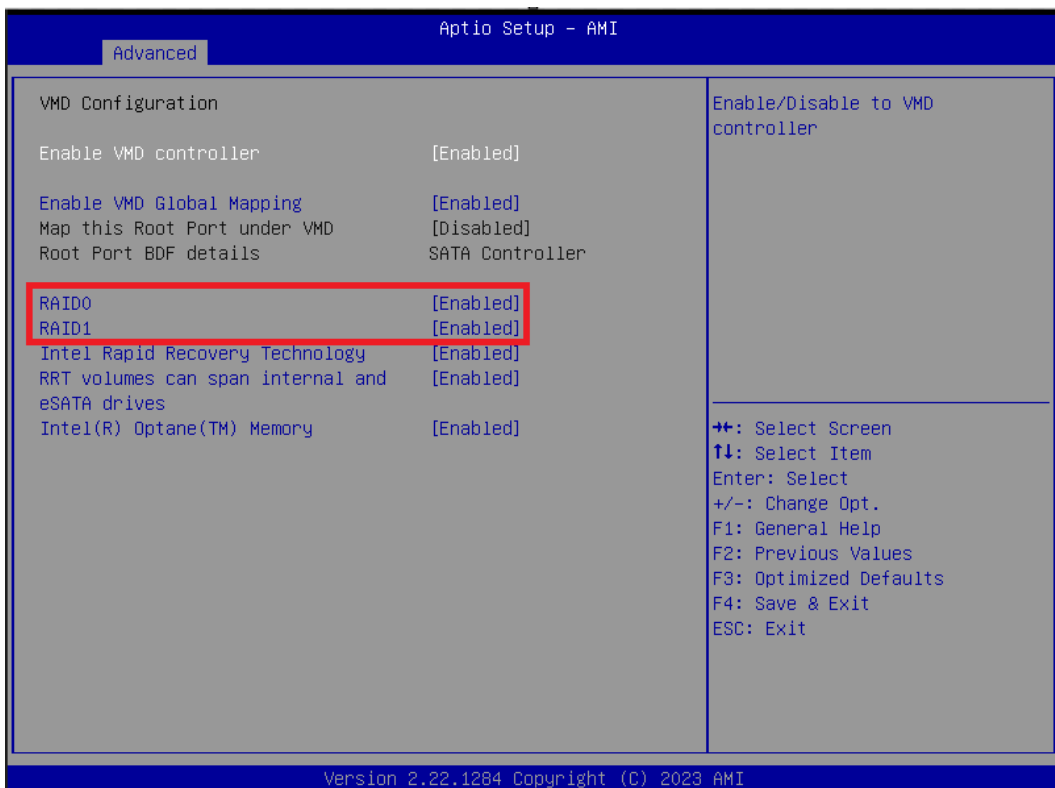
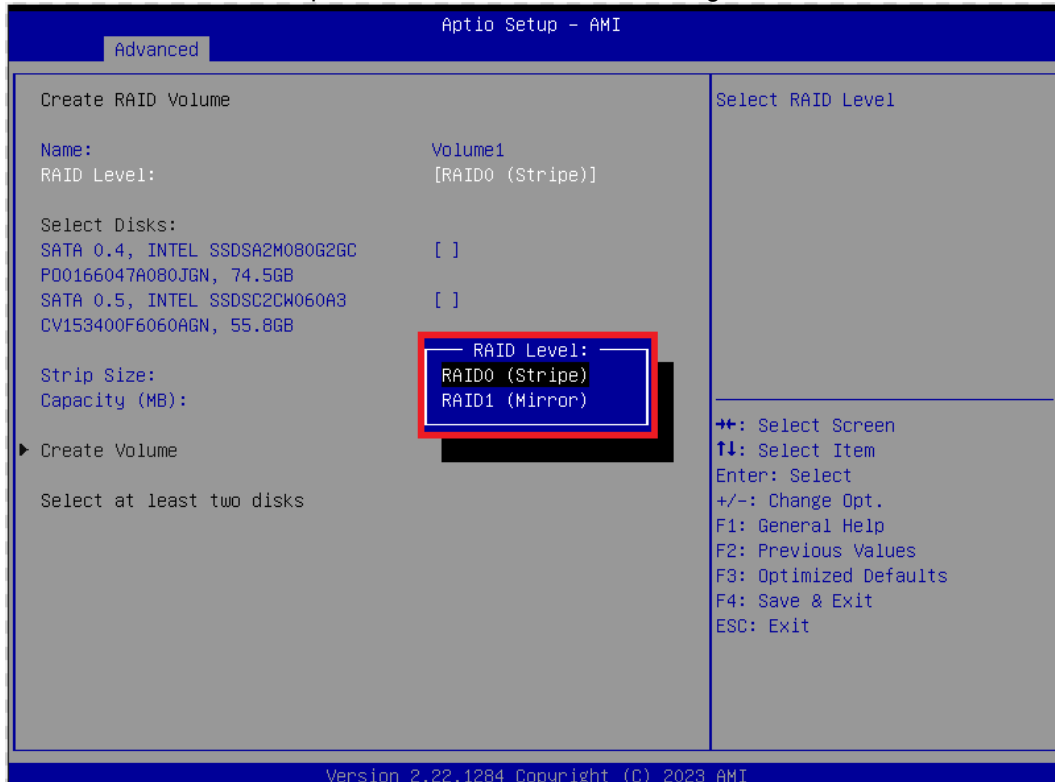

Step 5.
Select the disk to be merged.

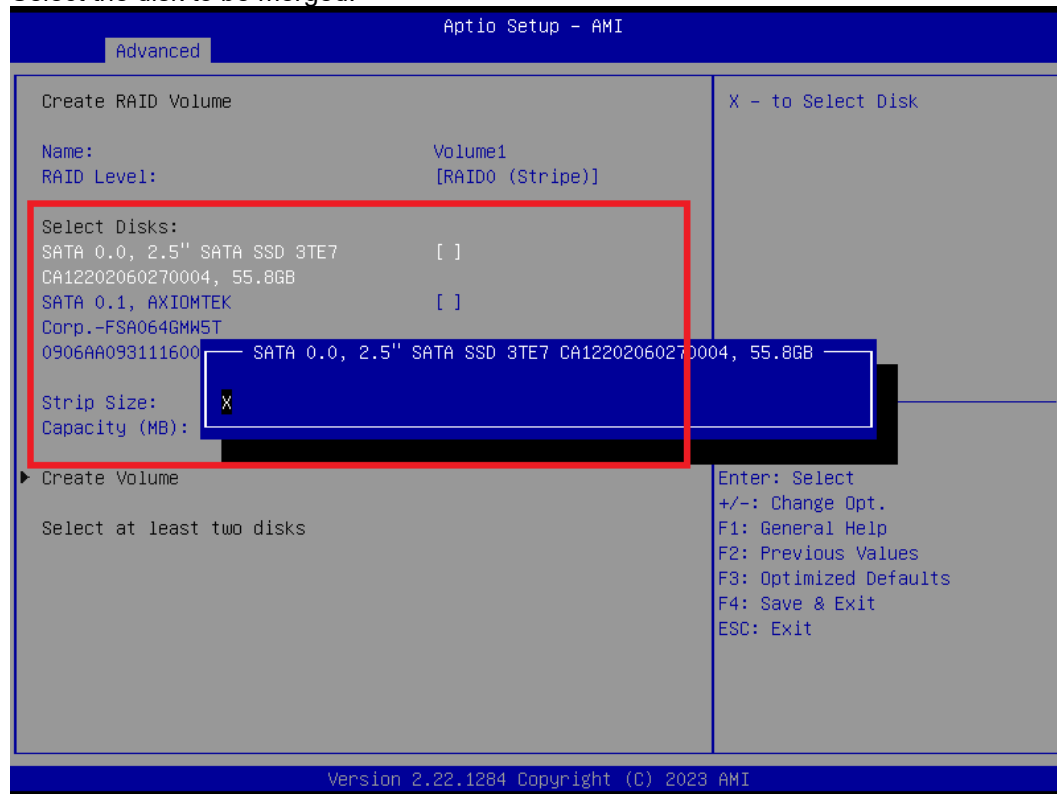

Step6.
Finally, implement create Volume.

